



# Chunghwa Picture Tubes, Ltd.

## Technical Specification

To :

Date : 2009/09/01

**TFT LCD**  
**CLAA156WA11A**

ACCEPTED BY :

| APPROVED BY  | CHECKED BY | PREPARED BY |
|--------------|------------|-------------|
| Ronald Huang | Roger Liu  | Carol Shen  |

Prepared by : TFT-LCD Product Planning Management Division

**CHUNGHWA PICTUER TUBES, LTD.**

1127 Hopin Rd., Padeh, Taoyuan, Taiwan 334, R.O.C.

TEL: +886-3-3675151 FAX: +886-3-377-3003

|         |                         |             |            |
|---------|-------------------------|-------------|------------|
| Doc.No: | CLAA156WA11A-2009/09/01 | Issue Date: | 2009/09/01 |
|---------|-------------------------|-------------|------------|

**RECORD OF REVISIONS**

| <b>Revision No.</b> | <b>Date</b>       | <b>Description</b>  |
|---------------------|-------------------|---------------------|
| <b>Tentative</b>    | <b>2008/09/15</b> | <b>First issued</b> |
|                     |                   |                     |
|                     |                   |                     |
|                     |                   |                     |
|                     |                   |                     |
|                     |                   |                     |
|                     |                   |                     |
|                     |                   |                     |
|                     |                   |                     |
|                     |                   |                     |
|                     |                   |                     |
|                     |                   |                     |
|                     |                   |                     |
|                     |                   |                     |
|                     |                   |                     |



## 1.OVERVIEW

CLAA156WA11A is 15.6" color (16 : 9) TFT-LCD (Thin Film Transistor Liquid Crystal Display) module composed of LCD panel, LVDS driver ICs, control circuit and backlight. By applying 6 bit digital data, 1366×RGB (3) ×768, 262K-color images are displayed on the 15.6" diagonal screen. general specifications are summarized in the following table :

| ITEM                            | SPECIFICATION  |
|---------------------------------|--|
| Display Area (mm)               | 344.232 (H)x193.536 (V) (15.6-inch diagonal)   |
| Number of Pixels                | 1366 ×3(H)×768 (V)   |
| Pixel Pitch (mm)                | 0.252 (H)×0.252(V)   |
| Color Pixel Arrangement         | RGB vertical stripe  |
| Display Mode                    | Normally white   |
| Number of Colors                | 262,144(6bits)(LVDS)   |
| Gamut                           | 56%(min)/60%(typ)  |
| Optimum Viewing Angle           | 6 o'clock  |
| Response Time (ms)              | 8ms (Typ)  |
| Surface Treatment               | Glare  |
| Viewing Angle                   | 40°、40°/15°、30°(Min.)  |
| Brightness (cd/m <sup>2</sup> ) | 220 cd/m <sup>2</sup> (5point)/6 mA (Typ.)<br>200 cd/m <sup>2</sup> (5point)/6 mA (Min.) |
| Uniformity                      | 5point : 80%   |
| Consumption of Power (W)        | 6.15W (Max )   |
| Module Size (mm)                | 359.8(W)×210(H)×5.5(D) ( Max )   |
| Module Weight (g)               | 450 (max)  |

The LCD Products listed on this document are not suitable for use of aerospace equipment, submarine cable, and nuclear reactor control system and life support systems. If customers intend to use these LCD products for applications listed above or those not included in the "Standard" list as follows, please contact our sales in advance.

Standard : Computer, Office equipment, Communication equipment, Test and Measurement equipment, Machine tool, Industrial robot, Audio and Visual equipment, Other consumer products.

Ps. "( )" is the tentative item.

## 2. ABSOLUTE MAXIMUM RATINGS

The following are maximum value, which if exceeded, may cause faulty operation or damage to the unit.

| ITEM                         | SYMBOL         | MIN. | MAX. | UNIT | REMARK          |
|------------------------------|----------------|------|------|------|-----------------|
| Power Supply Voltage for LCD | VCC            | 0    | 4.0  | V    |                 |
| LED Driver Input Voltage     | VBL+           | 7.5  | 21   | V    |                 |
| LED Driver Input Current     | IBL+           | TBD  | TBD  | mA   |                 |
| PWM Frequency                | PWM_BL         | TBD  | TBD  | KHz  | *7)             |
| LED Forward Voltage          | V <sub>F</sub> | 3.0  | 3.5  | V    |                 |
| LED Forward Current          | I <sub>F</sub> | -    | 30   | mA   | *1).2)          |
| Operation Temperature        | Top            | 0    | 50   | °C   | *3). 4). 5). 6) |
| Storage Temperature          | Tstg           | -25  | 65   | °C   | *3). 4). 5)     |

### 【Note】

- \*1) Product life-time relate to LED current, please operate production follow statement at page 9 “(b)back light” .
- \*2) When LED current over the definition of absolute max, product life-time will decay rapidly or operate unusual.
- \*3) The relative temperature and humidity range are as below sketch, 90%RH Max. ( $T_a \leq 40^\circ\text{C}$ )
- \*4) The maximum wet bulb temperature  $\leq 39^\circ\text{C}$  ( $T_a > 40^\circ\text{C}$ ) and without dewing.
- \*5) If product in environment which over the definition of the relative temperature and humidity out of range too long, it will affect visual of LCD.
- \*6) If you operate LCD in normal temperature range, the center surface of panel should be under  $50^\circ\text{C}$ .
- \*7) The External PWM frequency's typical value is 10 KHz with an amplitude of 3.3V .

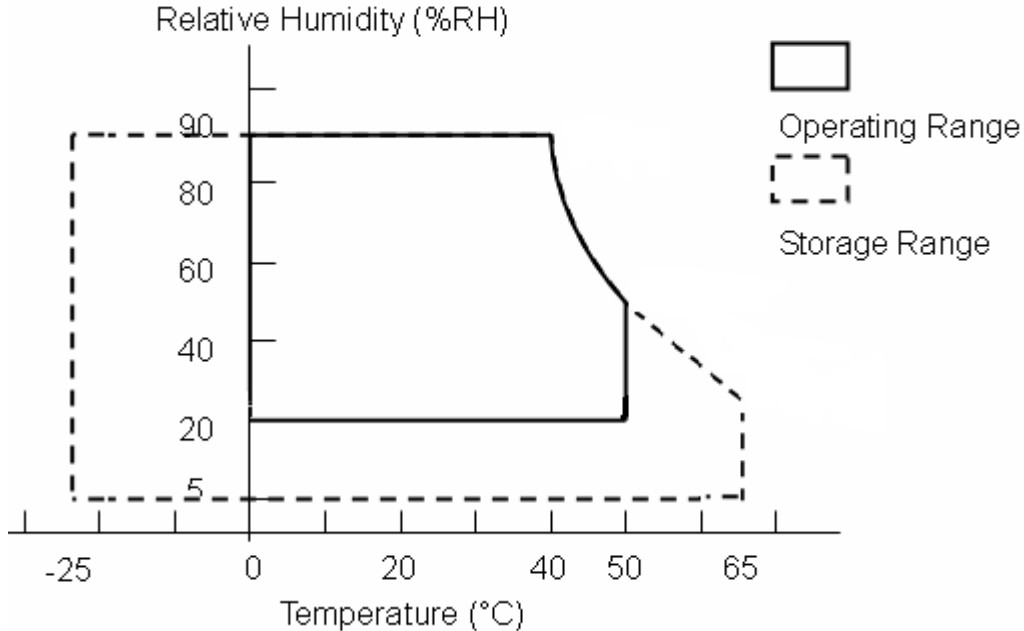

### 3. ELECTRICAL CHARACTERISTICS

#### (A) TFT LCD

| TEM                                 | SYMBOL                    | MIN | TYP   | MAX   | UNIT  | REMARK   |                              |
|-------------------------------------|---------------------------|-----|-------|-------|-------|----------|------------------------------|
| LCD POWER VOLTAGE                   | VCC                       | 3.0 | 3.3   | 3.6   | V     | 【Note 1】 |                              |
| LCD POWER CURRENT                   | ICC                       | -   | (400) | (500) | mA    | 【Note 2】 |                              |
| Rush CRRENT                         | Irush                     | -   | -     | 2     | A     | 【Note 4】 |                              |
| LOGIC INPUT VOLTAGE (LVDS: IN+,IN-) | INPUT VOLTAGE             | VIN | 0     | -     | VCC   | V        | 【Note 3】                     |
|                                     | COMMON VOLTAGE            | VCM | 1.125 | 1.25  | 1.375 | V        | 【Note 3】                     |
|                                     | DIFFRENTIAL INPUT VOLTAGE | VID | 250   | 350   | 450   | mV       | 【Note 3】                     |
|                                     | THRESHOLD VOLTAGE (HIGH)  | VTH | -     | -     | 100   | mV       | 【Note 3】<br>When VCM = +1.2V |
|                                     | THRESHOLD VOLTAGE (LOW)   | VTL | -100  | -     | -     | mV       |                              |
| DIFFRENTIAL INPUT VOLTAGE TOLERANCE | $\Delta$ VID              | -   | -     | 35    | mV    |          |                              |
| COMMON VOLTAGE TOLERANCE            | $\Delta$ VCM              | -   | -     | 35    | mV    |          |                              |

【Note 1】 Power Sequence :

|   |                          |
|---|--------------------------|
| $0.5 \text{ ms} \leq t1 \leq 10\text{ms}$ | $1 \text{ sec} \leq t4$  |
| $0.01 \text{ ms} < t2 \leq 50 \text{ ms}$ | $200 \text{ ms} \leq t5$ |
| $0.01 \text{ ms} < t3 \leq 50 \text{ ms}$ | $200 \text{ ms} \leq t6$ |

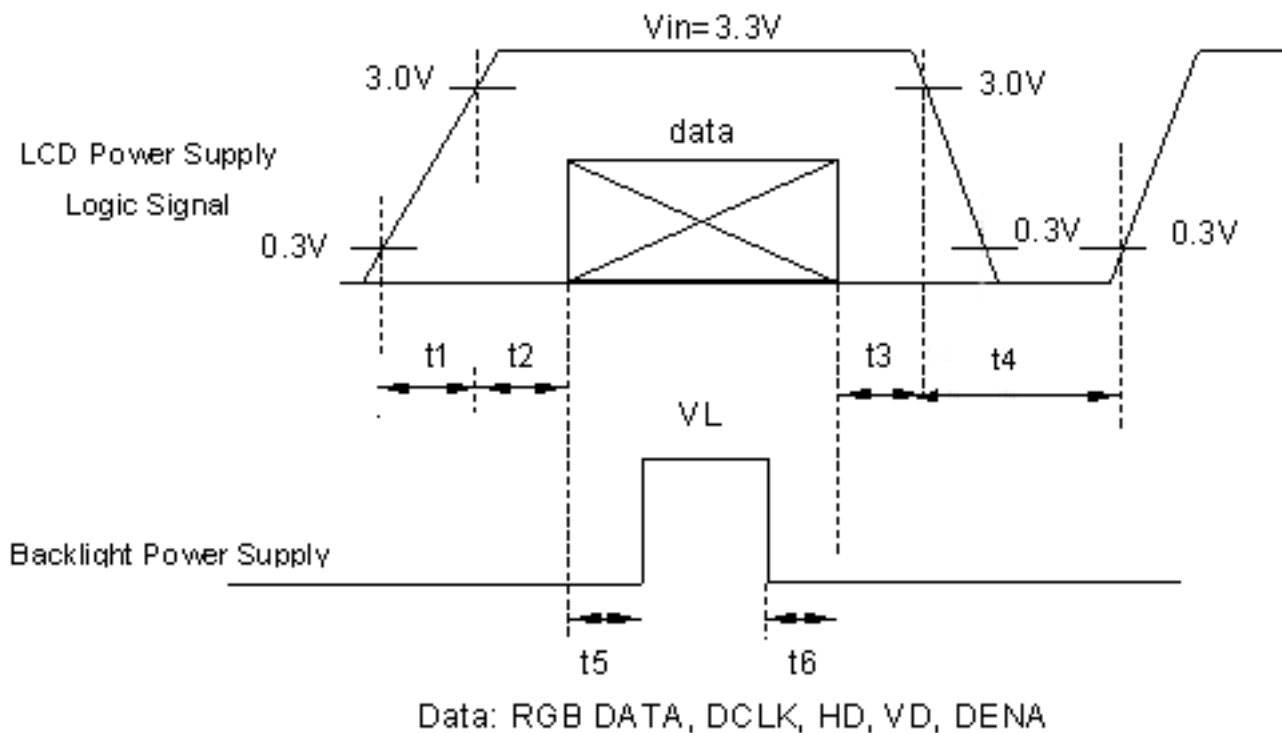

VCC-dip state

(1)when  $3.0 > VCC \geq 2.7V$  ,  $t_d \leq 10$  ms

(2)when  $VCC < 2.7V$  , VCC-dip condition should as the VCC-turn-off condition.

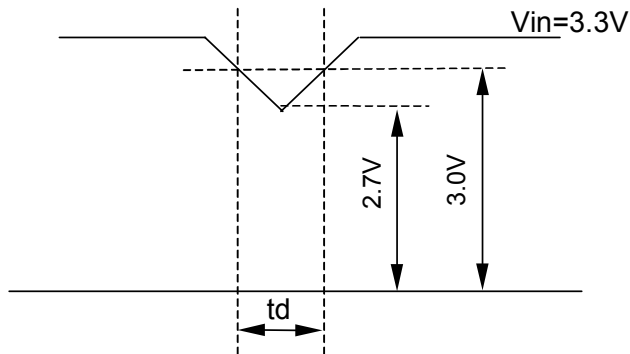

【Note 2】 Typical value is 0~63 gray level.(Horizontal line Pattern)

768 line mode , VCC= +3.3V

Circuit condition (Typ.) :

$VCC=3.3$  V ,  $f_v=60$  Hz  $f_H=48.36$  kHz ,  $f_{CLK}=75.44$  MHz

64-Gray

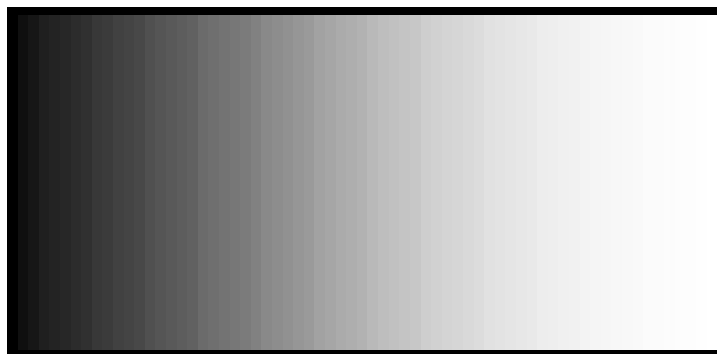

Circuit condition (Max.) :

$VCC=3.3$  V ,  $f_v=60$  Hz  $f_H=48.36$  kHz ,  $f_{CLK}=75.44$  MHz

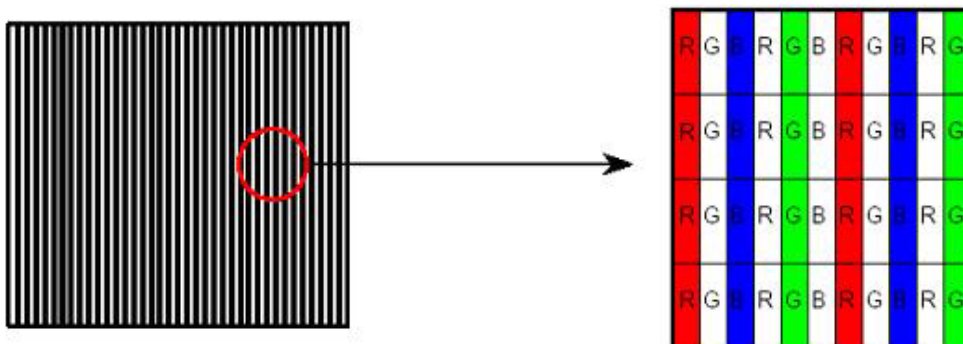



**(B) BACK LIGHT**

(a.) ELECTRICAL CHARACTERISTICS

Ta=25°C

| ITEM              | SYMBOL | MIN   | TYP   | MAX   | UNIT | REMARK               |
|-------------------|--------|-------|-------|-------|------|----------------------|
| Forward Voltage   | VF     | (3.0) | (3.2) | (3.5) | V    | I <sub>F</sub> =20mA |
| Forward Current   | IF     | (18)  | (20)  | (22)  | mA   | *1)                  |
| Power consumption | W      | TBD   | (64)  | TBD   | mW   | I <sub>F</sub> =20mA |

(b) LED LIFE – TIME

| ITEM      | Condition                      | min   | typ | max | UNIT | REMARK |
|-----------|--------------------------------|-------|-----|-----|------|--------|
| LIFE TIME | I <sub>F</sub> =20mA · Ta=25°C | 15000 |     |     | hrs  | *2)    |

\*1)Measure method : Galvanometer connect to low voltage

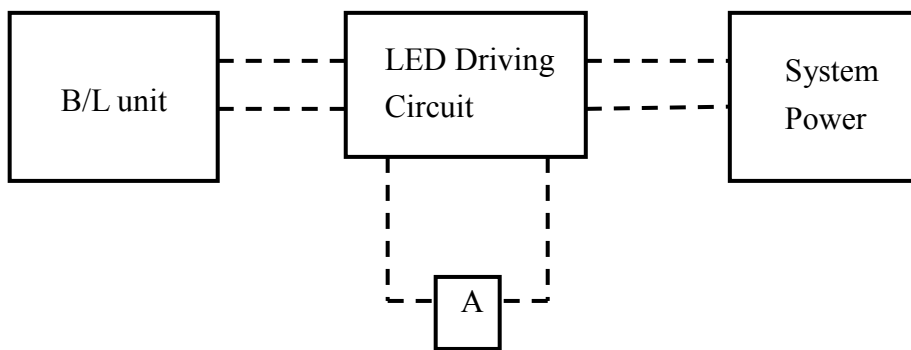

\*2)Life time means that estimated time to 50% degradation of initial luminous intensity.

## 4. Connector Interface PIN & Function

### CN(Interface signal)

Outlet connector: 20455-040E-02 (I-PEX)

| Pin No. | SYMBOL     | FUNCTION   |
|---------|------------|--|
| 1       | DIAG_LOOP  | Diag pin for Dell testing. Pin 1 & 34 must be connected together on the inverter board |
| 2       | VDD        | Power Supply, 3.3 V (typical)  |
| 3       | VDD        | Power Supply, 3.3 V (typical)  |
| 4       | V EEDID    | DDC 3.3V power   |
| 5       | NC         | No connection  |
| 6       | Ck EEDID   | DDC Clock  |
| 7       | DATA EEDID | DDC Data   |
| 8       | Odd_Rin0-  | - LVDS differential data input (R0-R5, G0) (odd pixels)                                |
| 9       | Odd_Rin0+  | + LVDS differential data input (R0-R5, G0) (odd pixels)                                |
| 10      | VSS        | Ground – Shield  |
| 11      | Odd_Rin1-  | - LVDS differential data input (G1-G5, B0-B1) (odd pixels)                             |
| 12      | Odd_Rin1+  | + LVDS differential data input (G1-G5, B0-B1) (odd pixels)                             |
| 13      | VSS        | Ground – Shield  |
| 14      | Odd_Rin2-  | - LVDS differential data input (B2-B5, HS, VS, DE) (odd pixels)                        |
| 15      | Odd_Rin2+  | + LVDS differential data input (B2-B5, HS, VS, DE) (odd pixels)                        |
| 16      | VSS        | Ground – Shield  |
| 17      | Odd_CkIN-  | - LVDS differential clock input (odd pixels)   |
| 18      | Odd_CkIN+  | + LVDS differential clock input (odd pixels)   |
| 19      | NC         | No connection  |
| 20      | NC         | No connection  |
| 21      | NC         | No connection  |
| 22      | NC         | No connection  |
| 23      | NC         | No connection  |
| 24      | NC         | No connection  |
| 25      | NC         | No connection  |
| 26      | NC         | No connection  |
| 27      | NC         | No connection  |
| 28      | NC         | No connection  |
| 29      | NC         | No connection  |
| 30      | NC         | No connection  |
| 31      | VSSLED     | Ground – LED   |
| 32      | VSSLED     | Ground – LED   |
| 33      | VSSLED     | Ground – LED   |
| 34      | DIAG_LOOP  | Diag pin for Dell testing. Pin 1 & 34 must be connected together on the inverter board |
| 35      | PWM        | System PWM Signal Input (+3.3V Swing)  |
| 36      | LED_EN     | LED enable pin (+3.3V Input)   |
| 37      | NC         | NC   |
| 38      | VDDLED     | 7.5V – 21V LED power   |
| 39      | VDDLED     | 7.5V – 21V LED power   |
| 40      | VDDLED     | 7.5V – 21V LED power   |

### 5. INTERFACE TIMING CHART

#### (1)(a). LVDS input time sequence

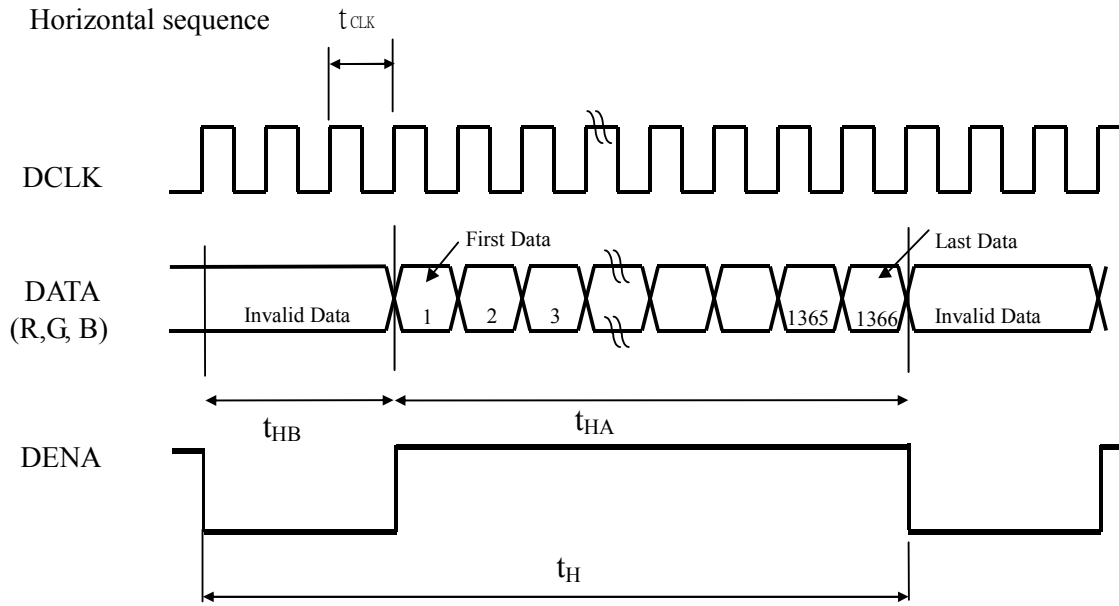

#### (b) LCD input time sequence

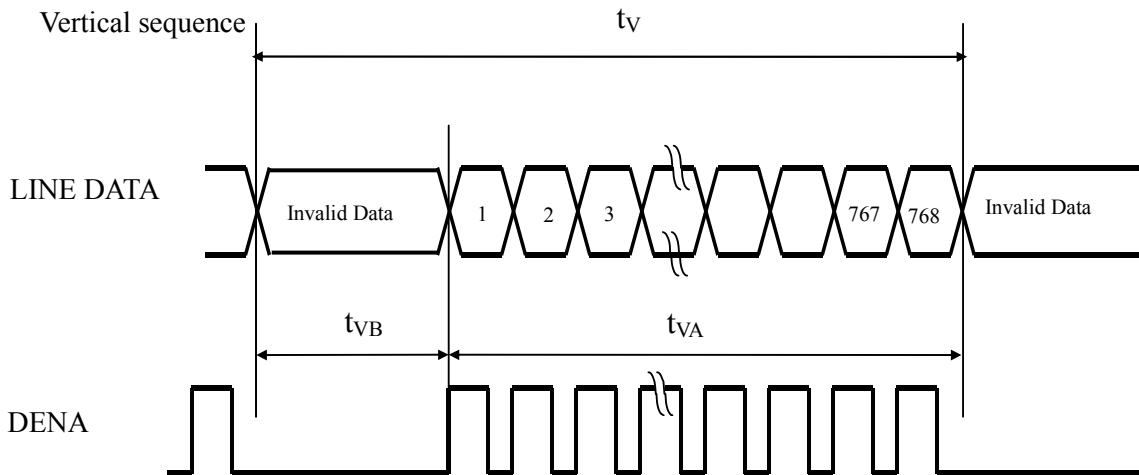

## (2) Timing Chart

| ITEM          |            |            | SYMBOL                 | MIN       | TYP   | MAX   | UNIT  |           |
|---------------|------------|------------|------------------------|-----------|-------|-------|-------|-----------|
| LCD<br>Timing | Frame Rate |            | -                      | 60        | 60    | 60    | Hz    |           |
|               | DCLK       |            | Frequency              | $f_{CLK}$ | 65.83 | 75.44 | 88.74 | MHz       |
|               |            |            | Period                 | $t_{CLK}$ | 11.26 | 13.25 | 15.19 | ns        |
|               | DENA       | Horizontal | Horizontal total time  | $t_H$     | 1414  | 1560  | 1700  | $t_{CLK}$ |
|               |            |            | Horizontal Active time | $t_{HA}$  | 1366  | 1366  | 1366  | $t_{CLK}$ |
|               |            |            | Horizontal Blank time  | $t_{HB}$  | 48    | 194   | 334   | $t_{CLK}$ |
|               |            | Vertical   | Vertical total time    | $t_V$     | 776   | 806   | 870   | $t_H$     |
|               |            |            | Vertical Active time   | $t_{VA}$  | 768   | 768   | 768   | $t_H$     |
|               |            |            | Vertical Blank time    | $t_{VB}$  | 8     | 38    | 114   | $t_H$     |

## 【Note】

- \*1) Data is latched during DCLK falling period.
- \*2) HD、VD is negative.
- \*3) DENA (DATA ENABLE) usually is positive.
- \*4) During the whole blank period, DCLK should keep input.  
During the vertical blank period, HD should keep input.

(3) DATA mapping

| Color       | Input Data | R DATA   |    |    |    |    |         | G DATA  |    |    |    |    |         | B DATA  |    |    |    |    |         |
|-------------|------------|----------|----|----|----|----|---------|---------|----|----|----|----|---------|---------|----|----|----|----|---------|
|             |            | R5       | R4 | R3 | R2 | R1 | R0      | G5      | G4 | G3 | G2 | G1 | G0      | B5      | B4 | B3 | B2 | B1 | B0      |
|             |            | MS<br>B  |    |    |    |    | LS<br>B | MS<br>B |    |    |    |    | LS<br>B | MS<br>B |    |    |    |    | LS<br>B |
| Basic Color | Black      | 0        | 0  | 0  | 0  | 0  | 0       | 0       | 0  | 0  | 0  | 0  | 0       | 0       | 0  | 0  | 0  | 0  | 0       |
|             | Red(63)    | 1        | 1  | 1  | 1  | 1  | 1       | 0       | 0  | 0  | 0  | 0  | 0       | 0       | 0  | 0  | 0  | 0  | 0       |
|             | Green(63)  | 0        | 0  | 0  | 0  | 0  | 0       | 1       | 1  | 1  | 1  | 1  | 1       | 0       | 0  | 0  | 0  | 0  | 0       |
|             | Blue(63)   | 0        | 0  | 0  | 0  | 0  | 0       | 0       | 0  | 0  | 0  | 0  | 0       | 1       | 1  | 1  | 1  | 1  | 1       |
|             | Cyan       | 0        | 0  | 0  | 0  | 0  | 0       | 1       | 1  | 1  | 1  | 1  | 1       | 1       | 1  | 1  | 1  | 1  | 1       |
|             | Magenta    | 1        | 1  | 1  | 1  | 1  | 1       | 0       | 0  | 0  | 0  | 0  | 0       | 1       | 1  | 1  | 1  | 1  | 1       |
|             | Yellow     | 1        | 1  | 1  | 1  | 1  | 1       | 1       | 1  | 1  | 1  | 1  | 1       | 0       | 0  | 0  | 0  | 0  | 0       |
|             | White      | 1        | 1  | 1  | 1  | 1  | 1       | 1       | 1  | 1  | 1  | 1  | 1       | 1       | 1  | 1  | 1  | 1  | 1       |
| RED         | RED(0)     | 0        | 0  | 0  | 0  | 0  | 0       | 0       | 0  | 0  | 0  | 0  | 0       | 0       | 0  | 0  | 0  | 0  | 0       |
|             | RED(1)     | 0        | 0  | 0  | 0  | 0  | 1       | 0       | 0  | 0  | 0  | 0  | 0       | 0       | 0  | 0  | 0  | 0  | 0       |
|             | RED(2)     | 0        | 0  | 0  | 0  | 1  | 0       | 0       | 0  | 0  | 0  | 0  | 0       | 0       | 0  | 0  | 0  | 0  | 0       |
|             | RED(62)    | 1        | 1  | 1  | 1  | 1  | 0       | 0       | 0  | 0  | 0  | 0  | 0       | 0       | 0  | 0  | 0  | 0  | 0       |
|             | RED(63)    | 1        | 1  | 1  | 1  | 1  | 1       | 0       | 0  | 0  | 0  | 0  | 0       | 0       | 0  | 0  | 0  | 0  | 0       |
|             | Green      | Green(0) | 0  | 0  | 0  | 0  | 0       | 0       | 0  | 0  | 0  | 0  | 0       | 0       | 0  | 0  | 0  | 0  | 0       |
| Green(1)    |            | 0        | 0  | 0  | 0  | 0  | 0       | 0       | 0  | 0  | 0  | 0  | 1       | 0       | 0  | 0  | 0  | 0  | 0       |
| Green(2)    |            | 0        | 0  | 0  | 0  | 0  | 0       | 0       | 0  | 0  | 0  | 1  | 0       | 0       | 0  | 0  | 0  | 0  | 0       |
| Green(62)   |            | 0        | 0  | 0  | 0  | 0  | 0       | 1       | 1  | 1  | 1  | 1  | 0       | 0       | 0  | 0  | 0  | 0  | 0       |
| Green(63)   |            | 0        | 0  | 0  | 0  | 0  | 0       | 1       | 1  | 1  | 1  | 1  | 1       | 0       | 0  | 0  | 0  | 0  | 0       |
| Blue        | Blue(0)    | 0        | 0  | 0  | 0  | 0  | 0       | 0       | 0  | 0  | 0  | 0  | 0       | 0       | 0  | 0  | 0  | 0  | 0       |
|             | Blue(1)    | 0        | 0  | 0  | 0  | 0  | 0       | 0       | 0  | 0  | 0  | 0  | 0       | 0       | 0  | 0  | 0  | 0  | 1       |
|             | Blue(2)    | 0        | 0  | 0  | 0  | 0  | 0       | 0       | 0  | 0  | 0  | 0  | 0       | 0       | 0  | 0  | 0  | 1  | 0       |
|             | Blue(62)   | 0        | 0  | 0  | 0  | 0  | 0       | 0       | 0  | 0  | 0  | 0  | 0       | 1       | 1  | 1  | 1  | 1  | 0       |
|             | Blue(63)   | 0        | 0  | 0  | 0  | 0  | 0       | 0       | 0  | 0  | 0  | 0  | 0       | 1       | 1  | 1  | 1  | 1  | 1       |

【Note】

- 1) Gray level:  
Color(n) : n is level order; higher n means brighter level.
- 2) DATA:  
1: high , 0: low

### 6. BLOCK DIAGRAM

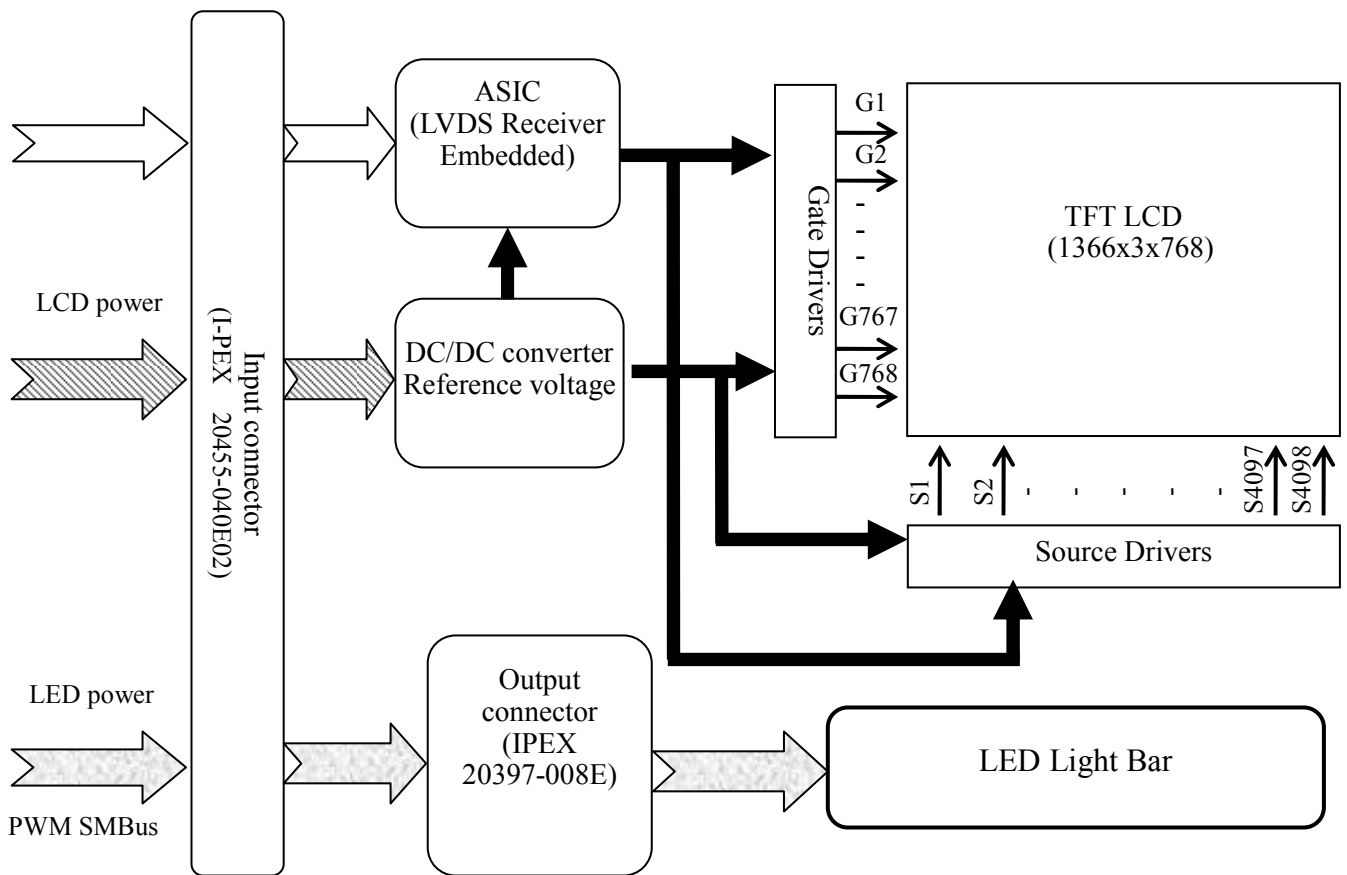





## 8. OPTICAL CHARACTERISTICS

Ta=25°C , VDD=3.3V

| ITEM                         | SYMBOL     | CONDITION                     | MIN.                      | TYP.    | MAX.    | UNIT              | REMARK |     |
|------------------------------|------------|-------------------------------|---------------------------|---------|---------|-------------------|--------|-----|
| Contrast Ratio               | CR         | $\theta = \psi = 0^\circ$     | 400                       | 600     |         | --                | *1) 2) |     |
| Luminance (5P)               | L          | $\theta = \psi = 0^\circ$     | 200                       | 220     |         | cd/m <sup>2</sup> | *1) 3) |     |
| Uniformity(5P)               | $\Delta L$ | $\theta = \psi = 0^\circ$     | 80                        |         |         | %                 | *1) 3) |     |
| Response Time                | Tr         | $\theta = \psi = 0^\circ$     |                           | 3       | 6       | ms                | *5)    |     |
|                              | Tf         | $\theta = \psi = 0^\circ$     |                           | 5       | 10      | ms                | *5)    |     |
| Cross talk                   | CT         | $\theta = \phi = 0^{\circ*3}$ |                           |         | 1       | %                 | *6)    |     |
| View angle                   | Horizontal | $\Psi$                        | $CR \geq 10$              | 40/-40  | 45/-45  |                   | °      | *4) |
|                              | Vertical   | $\theta$                      |                           | 15/-30  | 20/-35  |                   | °      | *4) |
| Color Temperature Coordinate | W          | X                             | $\theta = \psi = 0^\circ$ | 0.283   | 0.313   | 0.343             | *3)    |     |
|                              |            | Y                             |                           | 0.299   | 0.329   | 0.359             |        |     |
|                              | R          | X                             |                           | (0.590) | (0.620) | (0.650)           |        |     |
|                              |            | Y                             |                           | (0.310) | (0.340) | (0.370)           |        |     |
|                              | G          | X                             |                           | (0.300) | (0.330) | (0.360)           |        |     |
|                              |            | Y                             |                           | (0.540) | (0.570) | (0.600)           |        |     |
| B                            | X          | (0.120)                       | (0.150)                   | (0.180) |         |                   |        |     |
|                              | Y          | (0.030)                       | (0.060)                   | (0.090) |         |                   |        |     |
| Gamut                        |            | $\theta = \psi = 0^\circ$     | 56%                       | 60%     |         |                   | *7)    |     |

All the other items are measured by BM-5A (TOPCON). All these items are measured under the dark room condition (no ambient light).

Measurement Condition: IL=20mA(each LED)

### Definition of these measurement items is as follows:

#### \*1) Setup of Measurement Equipment

The LCD module should be turn-on to a stable luminance level to be reached. The measurement should be executed after lighting Backlight for 20 minutes and in a dark room.

#### \*2) Definition of Contrast Ratio

CR=ON (White) Luminance/OFF (Black) Luminance

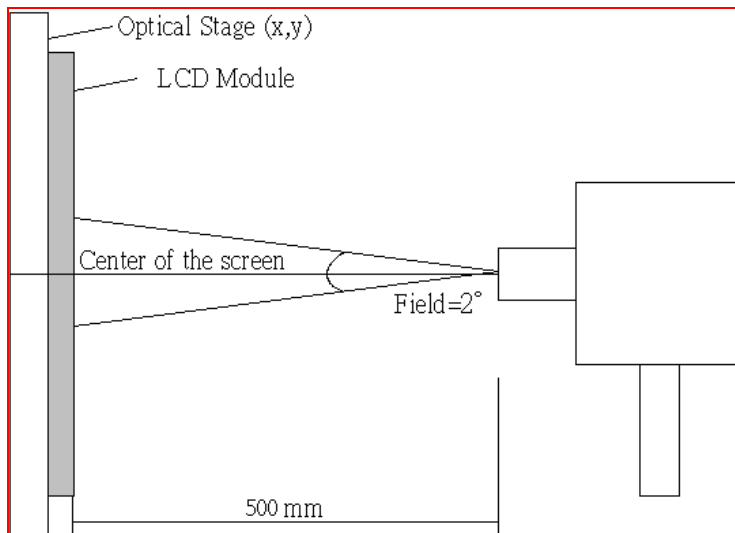

**\*3) Definition of Luminance and Luminance uniformity**

Central luminance: The white luminance is measured at the center position “5” on the screen, see Fig.1 below.

5P Luminance (AVG): The white luminance is measured at measuring points 5、10、11、12、13, see Fig.1 below.

5P Uniformity:  $\Delta L = (L_{min} / L_{max}) \times 100\%$

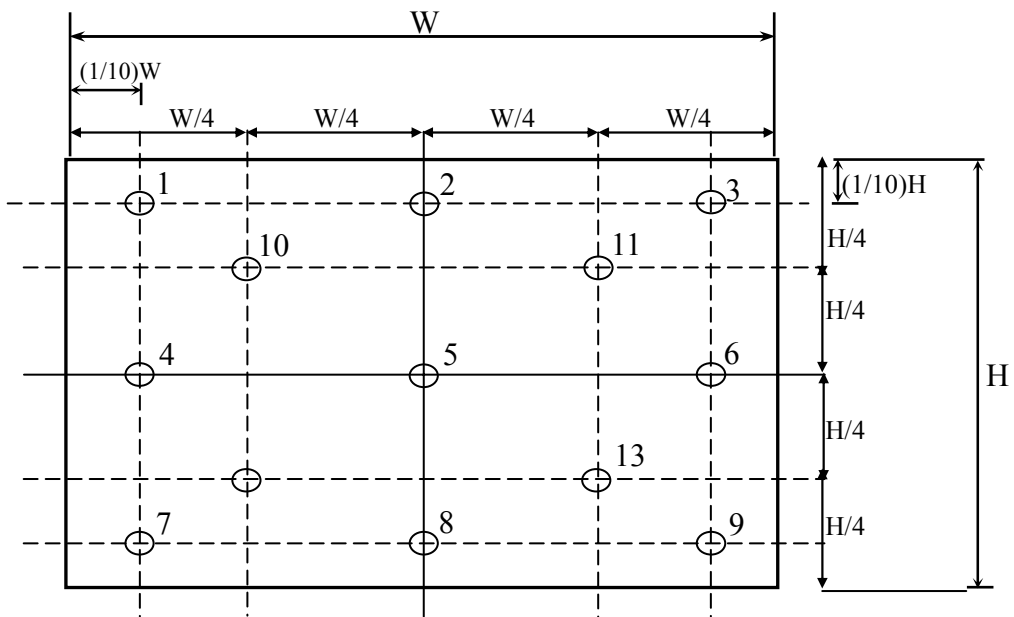
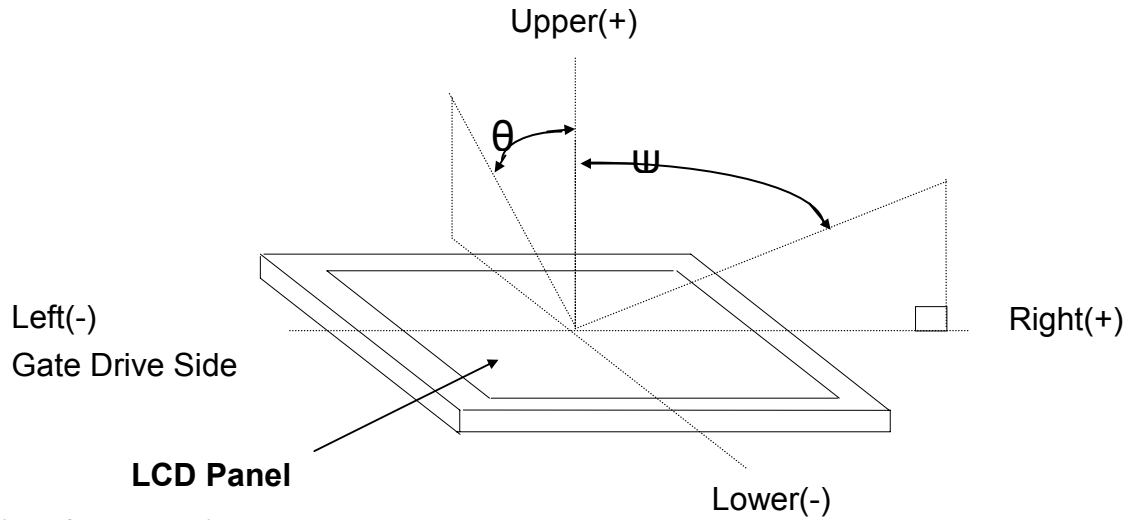
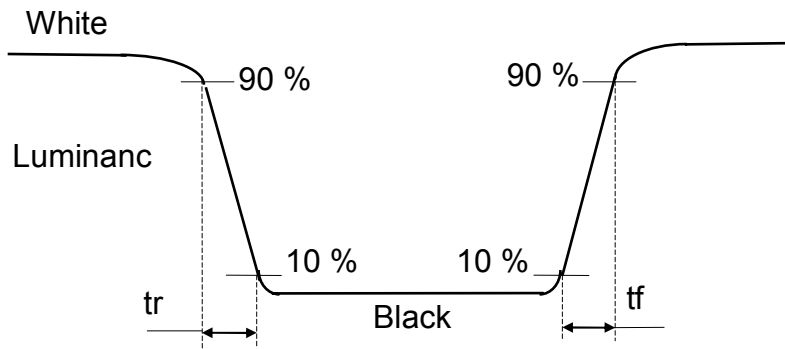

Fig.1 Measure point (Active area)

**\*4) Definition of view angle( $\theta$  ,  $\psi$ )**



**\*5) Definition of response time**



**\*6) Definition of image sticking :**

Continuously display the test pattern shown in the figure below for 16 hrs. At 25°C.

To change the picture to gray pattern (gray 32 pattern), and the previous image shall not persist during 20 min.

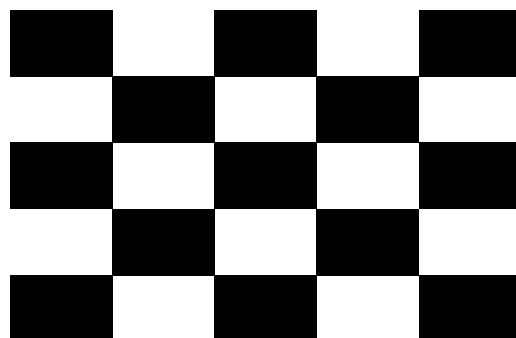

White : 63 Gray

Black : 0 Gray

**\*7) Crosstalk Modulation Ratio:**

$$CT = | Y_B - Y_A | / Y_A \times 100\%$$

$Y_A$ 、 $Y_B$  measure position and definition

$Y_A$  means luminance at gray level 32(exclude gray level 0 pattern)

$Y_B$  means luminance at gray level 32(include gray level 0 pattern)

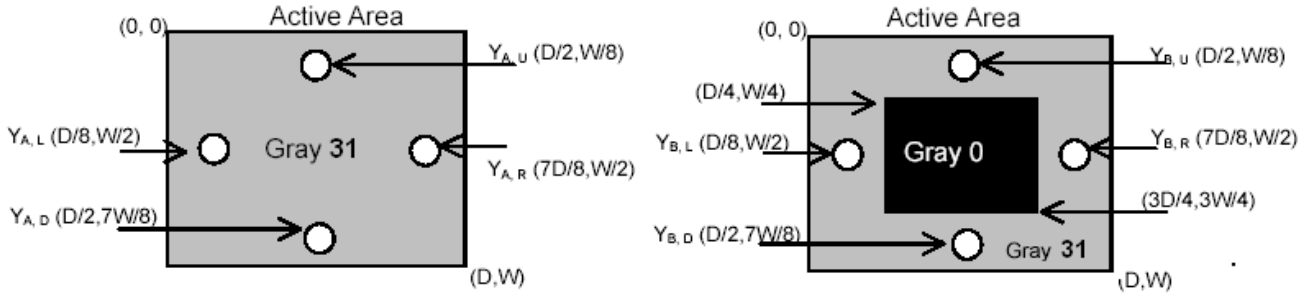

## 9. RELIABILITY TEST CONDITIONS

### (1) Temperature · Humidity and Pressure

| TEST ITEMS                               | CONDITIONS  |
|--|---|
| High Temperature Operation               | 50° C ; 250Hrs                                    |
| High Temperature Storage                 | 65° C ; 250Hrs                                    |
| High Temperature High Humidity Operation | 40° C ; 95% RH ; 250Hrs                           |
| High Temperature High Humidity Storage   | 60° C ; 95% RH ; 48 Hrs                           |
| Low Temperature Operation                | 0° C ; 250 Hrs                                    |
| Low Temperature Storage                  | -25° C ; 250 Hrs                                  |
| Thermal Shock                            | -40° C (30 Mins) ~ 65° C (30 Mins) ,<br>100 CYCLE |
| Low Temperature Low Pressure Storage     | 0° C 、 260hPa 、 24 Hrs                            |

### (2) Shock & Vibration

| TEST ITEMS                   | CONDITIONS   |
|------------------------------|--|
| Shock<br>(Non-Operation)     | Shock level : 2450m/s <sup>2</sup> (250G), Waveform : half sinusoidal wave,<br>2ms, 6 axis (± X, ± Y, ± Z) per cycle   |
| Vibration<br>(Non-Operation) | Vibration level : 14.7m/s <sup>2</sup> (1.5G), sinusoidal wave (each x, y, z axis :<br>1hr, total 3hrs)<br>Frequency range : 5 ~ 500 Hz<br>Sweep speed : 0.5 Octave/min. |

### (3) ESD

|                     | Surface discharge<br>(Panel display area · Frame) |            | Electrics capacity of<br>Connector |
|---------------------|---|------------|------------------------------------|
|                     | Contact   | Air        | Contact                            |
| Capacity            | 150 pF  | 150 pF     | 200 pF                             |
| Resistance          | 330 Ω   | 330 Ω      | 0 Ω                                |
| Voltage             | ±8kV  | ±8kV/±15kV | ±250 V                             |
| Interval            | 1 sec   | 1 sec      | 1 sec                              |
| Times(single point) | 25  | 25         | 1                                  |

### (4) MTBF without B/L : 200,000 Hrs(min) lifetime.

### (5) Judgment standard

The judgment of the above test should be made as follow:

Pass : Normal display image with no obvious non-uniformity and no line defect.

Partial transformation of the module parts should be ignored.

Fail : No display image, obvious non-uniformity, or line defects.

## 10. HANDLING PRECAUTIONS FOR TFT-LCD MODULE

Please pay attention to the followings in handling- TFT-LCD products;

### 10.1 ASSEMBLY PRECAUTION

- (1) Please use the mounting hole on the module side in installing and do not beading or wrenching LCD in assembling. And please do not drop, bend or twist LCD module in handling.
- (2) Please design display housing in accordance with the following guidelines.
  - Housing case must be destined carefully so as not to put stresses on LCD all sides and not to wrench module. The stresses may cause non-uniformity even if there is no non-uniformity statically.
  - Keep sufficient clearance between LCD module back surface and housing when the LCD module is mounted. Approximately 1.0 mm of the clearance in the design is recommended taking into account the tolerance of LCD module thickness and mounting structure height on the housing.
  - When some parts, such as, FPC cable and ferrite plate, are installed underneath the LCD module, still sufficient clearance is required, such as 0.5mm. This clearance is, especially, to be reconsidered when the additional parts are implemented for EMI countermeasure.
  - Design the inverter location and connector position carefully so as not to give stress to lamp cable, or not to interface the LCD module by the lamp cable.
  - Keep sufficient clearance between LCD module and the others parts, such as inverter and speaker so as not to interface the LCD module. Approximately 1.0mm of the clearance in the design is recommended.
- (3) Please do not push or scratch LCD panel surface with any-thing hard. And do not soil LCD panel surface by touching with bare hands. (Polarizer film, surface of LCD panel is easy to be flawed.)
- (4) Please do not press any parts on the rear side such as source TCP, gate TCP, control circuit board and FPCs during handling LCD module. If pressing rear part is unavoidable, handle the LCD module with care not to damage them.
- (5) Please wipe out LCD panel surface with absorbent cotton or soft clothe in case of it being soiled.
- (6) Please wipe out drops of adhesives like saliva and water on LCD panel surface immediately. They might damage to cause panel surface variation and color change.
- (7) Please do not take a LCD module to pieces and reconstruct it. Resolving and reconstructing modules may cause them not to work well.
- (8) Please do not touch metal frames with bare hands and soiled gloves. A color change of the metal frames can happen during a long preservation of soiled LCD modules.
- (9) Please pay attention to handling lead wire of backlight so that it is not tugged in connecting with inverter.

### 10.2 OPERATING PRECAUTIONS

- (1) Please be sure to turn off the power supply before connecting and disconnecting signal input cable.
- (2) Please do not change variable resistance settings in LCD module. They are adjusted to the most suitable value. If they are changed, it might happen LCD does not satisfy the characteristics specification.
- (3) Please consider that LCD backlight takes longer time to become stable of radiation characteristics in low temperature than in room temperature.
- (4) A condensation might happen on the surface and inside of LCD module in case of sudden change of

ambient temperature.

- (5) Please pay attention to displaying the same pattern for very long time. Image might stick on LCD. If then, time going on can make LCD work well.
- (6) Please obey the same caution descriptions as ones that need to pay attention to ordinary electronic parts.

### 10.3 PRECAUTIONS WITH ELECTROSTATICS

- (1) This LCD module use CMOS-IC on circuit board and TFT-LCD panel, and so it is easy to be affected by electrostatics. Please be careful with electrostatics by the way of your body connecting to the ground and so on.
- (2) Please remove protection film very slowly on the surface of LCD module to prevent from electrostatics occurrence.

### 10.4 STORAGE PRECAUTIONS

- (1) When you store LCDs for a long time, it is recommended to keep the temperature between 0°C ~40°C without the exposure of sunlight and to keep the humidity less than 90%RH.
- (2) Please do not leave the LCDs in the environment of high humidity and high temperature such as 60°C 90%RH.
- (3) Please do not leave the LCDs in the environment of low temperature; below -20°C.

### 10.5 SAFETY PRECAUTIONS

- (1) When you waste LCDs, it is recommended to crush damaged or unnecessary LCDs into pieces and wash them off with solvents such as acetone and ethanol, which should later be burned.
- (2) If any liquid leaks out of a damaged-glass cell and comes in contact with the hands, wash off thoroughly with soap and water.

### 10.6 OTHERS

- (1) A strong incident light into LCD panel might cause display characteristics' changing inferior because of polarizer film, color filter, and other materials becoming inferior. Please do not expose LCD module direct sunlight and strong UV rays.
- (2) Please pay attention to a panel side of LCD module not to contact with other materials in preserving it alone.
- (3) For the packaging box, please pay attention to the followings:
  - Packaging box and inner case for LCD are designed to protect the LCDs from the damage or scratching during transportation. Please do not open except picking LCDs up from the box.
  - Please do not pile them up more than 3 boxes. (They are not designed so.) And please do not turn over.
  - Please handle packaging box with care not to give them sudden shock and vibrations. And also please do not throw them up.
  - Packing box and inner case for LCDs are made of cardboard. So please pay attention not to get them wet. (Such like keeping them in high humidity or wet place can occur getting them wet.)

=