



Chunghwa Picture Tubes, Ltd.

Technical Specification

To : Geontek
Date : 2009/09/09

CPT TFT-LCD
CLAA116WA01A

Accepted by:
(Tentative)

APPROVED BY	CHECKED BY	PREPARED BY
黃奕凱	劉益群	賴建勛

Prepared by : Design General Division
CHUNGHWA PICTUER TUBES, LTD.

No. 1, Huaying Rd., Sanho Tsun, Lungtan Shiang, Taoyuan, Taiwan, 325, R.O.C.
TEL: +886-3-3675151 FAX: +886-3-377-3003

Doc. No:	CLAA116WA01A-Geontek-20090909	Issue Date:	20090909
----------	-------------------------------	-------------	----------

1. OVERVIEW

CLAA116WA01A is 29.3 cm (11.6") color TFT-LCD (Thin Film Transistor Liquid Crystal Display) module composed of LCD panel, driver ICs, control circuit and LED backlight. By applying 1366×768 images are displayed on the 11.6" diagonal screen. Display 262K colors by 6 Bit R.G.B signal input. Use 3.3 voltages to drive the power of LCD system. General specification is summarized in the following table :

ITEM	SPECIFICATION			
Display Area (mm)	256.125 (H) x 144.00 (V) (11.6-inch diagonal)			
Number of Pixels	1366(H) × 3(RGB) × 768(V)			
Pixel Pitch (mm)	0.1875 (H) × 0.1875 (V)			
Color Pixel Arrangement	RGB vertical stripe			
Display Mode	Normally white, TN			
Number of Colors	262,144			
Optimum Viewing Angle	6 o'clock			
Response Time (ms)	10ms			
Viewing Angle (L/R/U/D)	45°、45°/15°、30° (Typ.)			
Brightness(cd/m ²)-5 point average	200 (typ)			
Uniformity (Min)	5point : 80%			
Consumption of Power (W)	4.0W (Max)			
Module Weight (g)	255 (max)			
Backlight Unit	LED			
Electrical Interface(data)	LVDS			
Surface Treatment	Glare type , Hardness : 3H			
Module Size (mm)		Min.	Typ.	Max.
	Horizontal (H)	267.7	268	268.3
	Vertical (V)	161.2	161.5	161.8
	Depth (D)	--	--	5.2

The LCD Products listed on this document are not suitable for use of aerospace equipment, submarine cable, and nuclear reactor control system and life support systems. If customers intend to use these LCD products for applications listed above or those not included in the "Standard" list as follows, please contact our sales in advance.

Standard : Computer, Office equipment, Communication equipment, Test and Measurement equipment, Machine tool, Industrial robot, Audio and Visual equipment, Other consumer products.

2. ABSOLUTE MAXIMUM RATINGS

The following are maximum value, which if exceeded, may cause faulty operation or damage to the unit.

ITEM	SYMBOL	MIN.	MAX.	UNIT	NOTE
Power Supply Voltage for LCD	VCC	0	4.0	V	
Operation Temperature	Top	0	50	°C	*1). 2). 3). 4)
Storage Temperature	Tstg	-25	65	°C	*1). 2). 3)

【Note】

- *1) The relative temperature and humidity range are as below sketch, 90%RH Max. ($T_a \leq 40^\circ\text{C}$)
- *2) The maximum wet bulb temperature $\leq 39^\circ\text{C}$ ($T_a > 40^\circ\text{C}$) and without dewing.
- *3) If product in environment which over the definition of the relative temperature and humidity out of range too long, it will affect visual of LCD.
- *4) If you operate LCD in normal temperature range, the center surface of panel should be under 50°C .

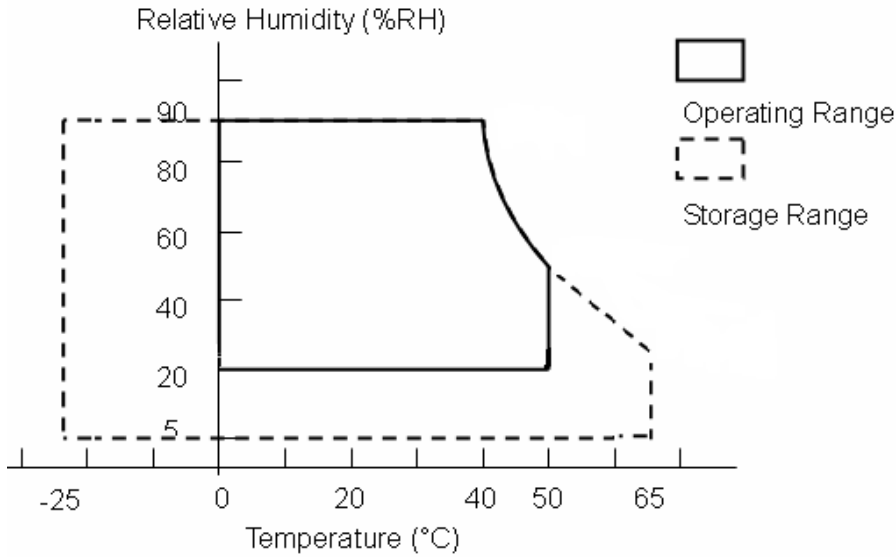

3. ELECTRICAL CHARACTERISTICS

(A) TFT LCD

TEM	SYMBOL	MIN	TYP	MAX	UNIT	NOTE	
LCD POWER VOLTAGE	VCC	3.0	3.3	3.6	V	【Note 1】	
LCD POWER CURRENT	ICC	-	350	400	mA	【Note 2】	
Rush CRRENT	Irush	-	-	1	A	【Note 4】	
LOGIC INPUT VOLTAGE (LVDS: IN+,IN-)	COMMON VOLTAGE	VCM	1.08	1.2	1.32	V	【Note 3】
	DIFFERENTIAL INPUT VOLTAGE	VID	250	350	450	mV	【Note 3】
	THRESHOLD VOLTAGE (HIGH)	VTH	-	-	100	mV	【Note 3】 When VCM = +1.2V
	THRESHOLD VOLTAGE (LOW)	VTL	-100	-	-	mV	

【Note 1】 Power Sequence :

- 0.5 ms ≤ t1 ≤ 10ms
- 0.01 ms < t2 ≤ 50 ms
- 0.01 ms < t3 ≤ 50 ms
- 1 sec ≤ t4
- 200 ms ≤ t5
- 200 ms ≤ t6

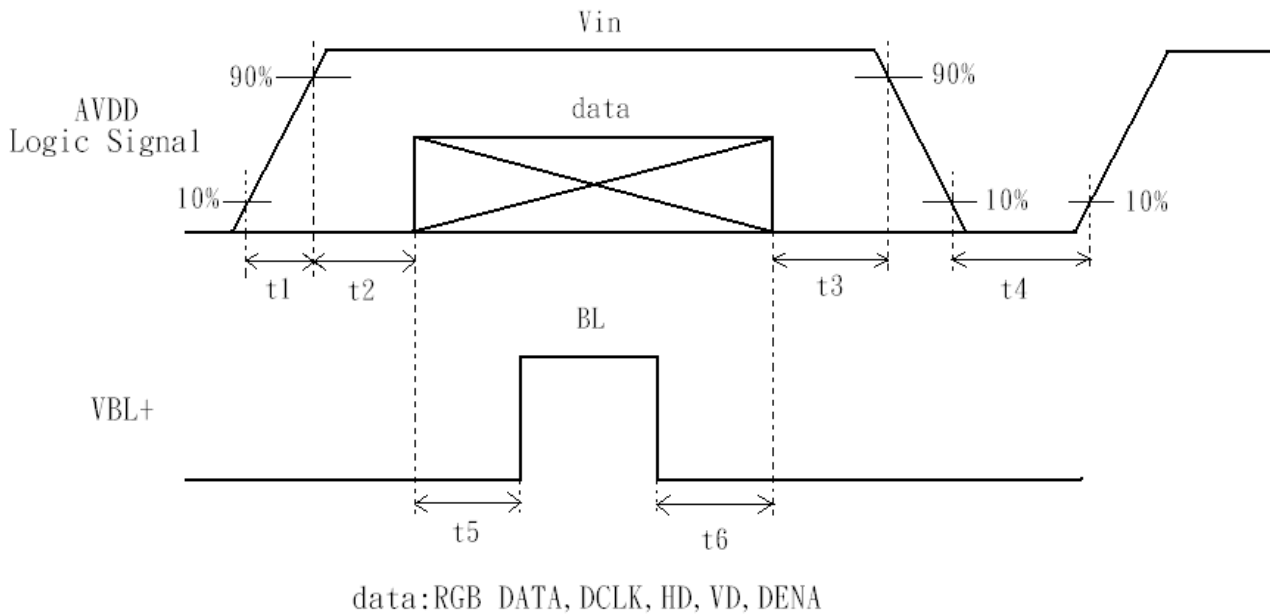

VCC-dip state

- (1) when $3.0 > VCC \geq 2.7V$, $t_d \leq 10$ ms
- (2) when $VCC < 2.7V$, VCC-dip condition should as the VCC-turn-off condition.

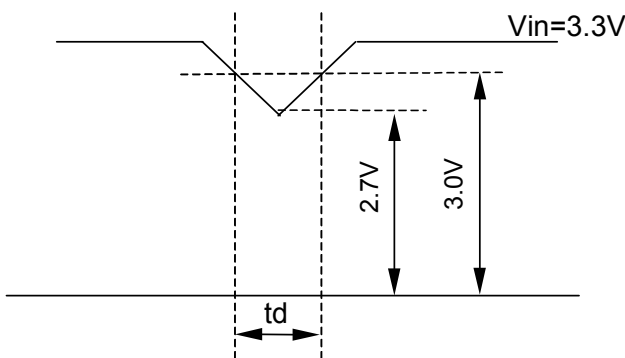

【Note2】 Typical value is Mosaic (32*36 Checker board) Pattern : 768 line mode ◦

Circuit condition (Typ.) :

VCC=3.3 V , $f_V=60$ Hz $f_H=48.36$ kHz , $f_{CLK}=75.44$ MHz

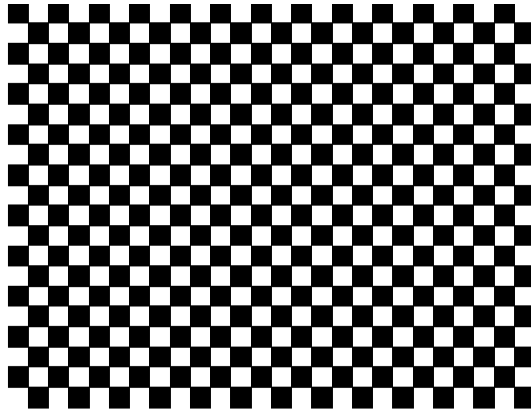

Max value is Black Pattern : 768 line mode ◦

Circuit condition (Max.) : VCC=3.3 V , $f_V=60$ Hz $f_H=48.36$ kHz , $f_{CLK}=75.44$ MHz

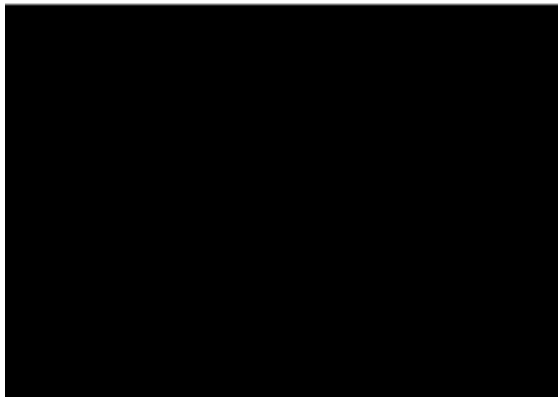

【Note 3】 LVDS Signal Definite :

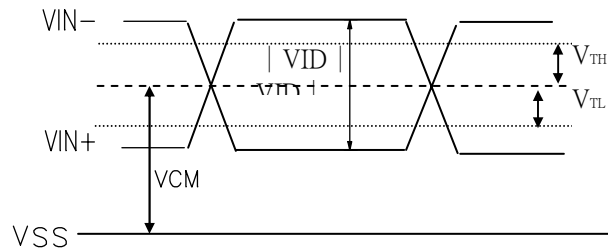
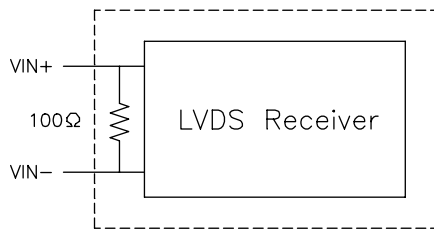

VIN+ : Positive differential DATA & CLK Input

VIN- : Negative differential DATA & CLK Input

【Note 4】 Irush measure condition

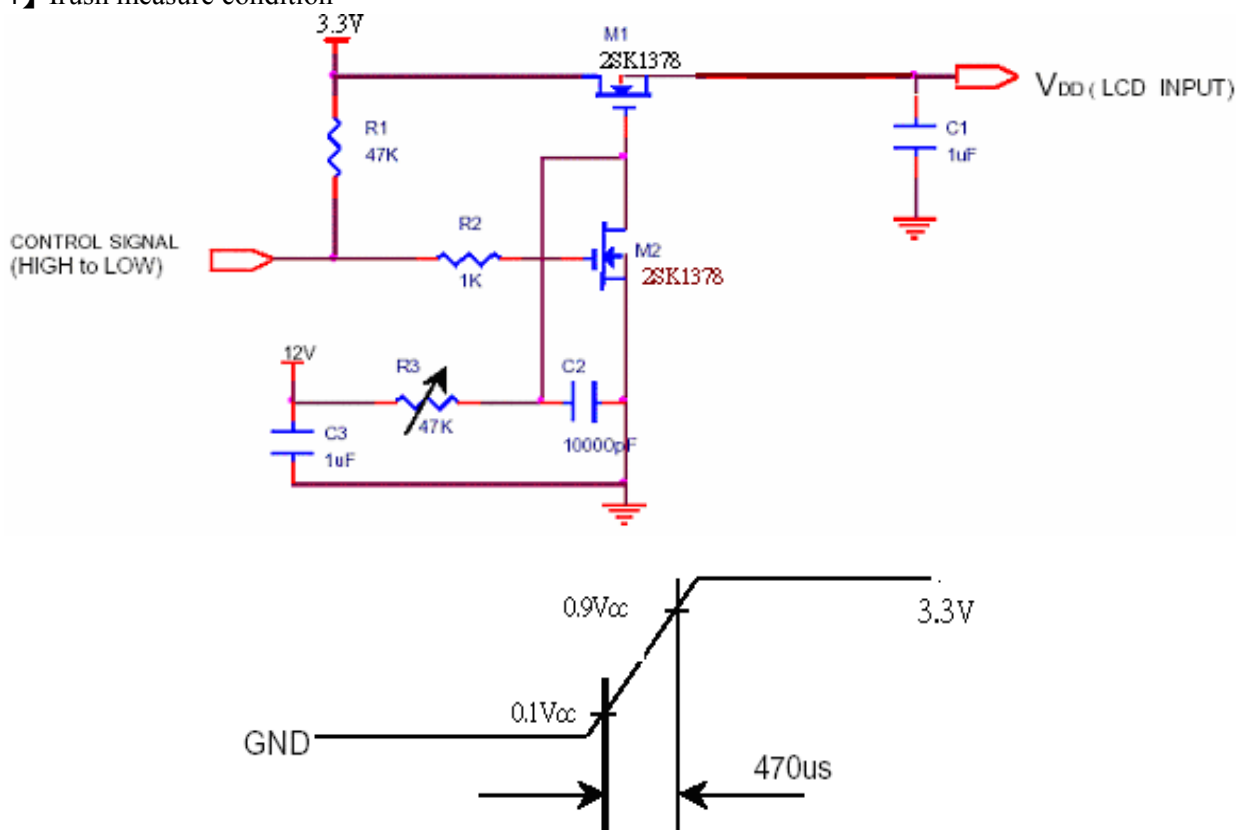

(B) BACK LIGHT

(a.) ELECTRICAL CHARACTERISTICS

ITEM	SYMBOL	MIN	TYP	MAX	UNIT	NOTE
LED Driver Input Voltage	VBL+	5	-	19	V	
LED Driver Input Current	IBL+	-	-	550	mA	VBL+=5V
Forward Voltage	VF	2.8	3.1	3.5	V	*1)I _F =20mA
Forward Current	I _F		20		mA	*1)
Power consumption	PLED	56	62	70	mW	*1)*2)I _F =18mA
PWM Frequency	PWM _{BL}	180	200	1k	Hz	
Duty ratio	Dim	10		100	%	

T_a=25°C

(b) LED LIFE - TIME

ITEM	Condition	min	typ	max	UNIT	NOTE
LIFE TIME	I _F =20mA、T _a =25°C	15000			hrs	*3)

(c) LED ON/OFF Sequence :

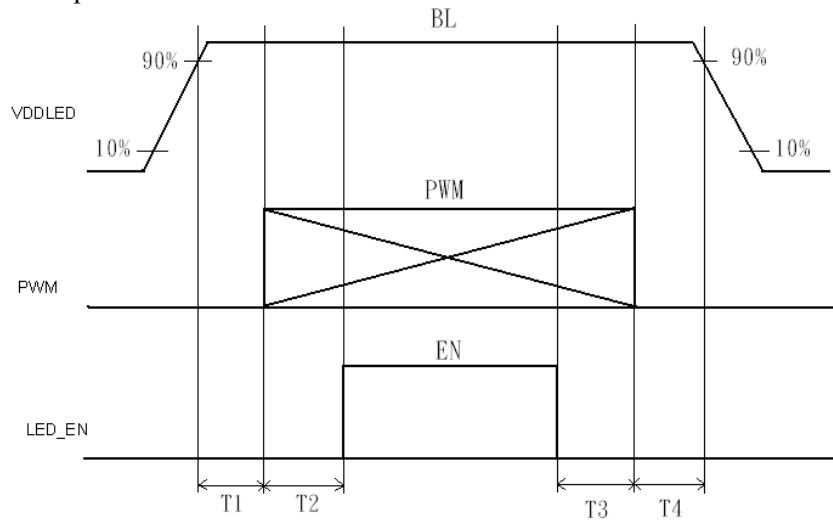

$$10\text{ms} \leq T1 \quad 0\text{ms} \leq T3$$

$$10\text{ms} \leq T2 \quad 10\text{ms} \leq T4$$

Note : The duty of LED dimming signal should be more than 20% in T2 and T3

- *1)Measure method : a. LED current is measured by utilizing a current meter as show below.
- b. we set up system power input voltage at 12v to measurement PLED.

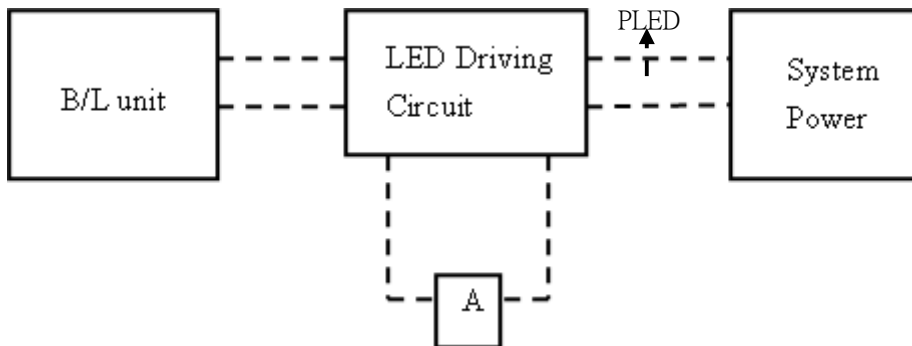

- *2) Calculator value for reference $IF \cdot VF = P$
- *3)Life time means that estimated time to 50% degradation of initial luminous intensity.

4. Connector Interface PIN & Function

CN(Interface signal)

Connector type : I-PEX 20455-040E-12 or compatible

Pin No.	SYMBOL	FUNCTION
1	NC	NC
2	V _{CC}	+3.3V Power
3	V _{CC}	+3.3V Power
4	V _{EDID}	EDID 3.3V Power
5	NC	No Connect
6	CLK _{EDID}	EDID Clock
7	DATA _{EDID}	EDID Data
8	RXIN0-	LVDS Signal(-)—channel 0
9	RXIN0+	LVDS Signal(+)—channel 0
10	GND	Ground
11	RXIN1-	LVDS Signal(-)—channel 1
12	RXIN1+	LVDS Signal(+)—channel 1
13	GND	Ground
14	RXIN2-	LVDS Signal(-)—channel 2
15	RXIN2+	LVDS Signal(+)—channel 2
16	GND	Ground
17	RXCLKIN-	LVDS Clock Signal(-)
18	RXCLKIN+	LVDS Clock Signal(+)
19	GND	Ground
20	NC	NC
21	NC	NC
22	GND	Ground
23	NC	NC
24	NC	NC
25	GND	Ground
26	NC	NC
27	NC	NC
28	GND	Ground
29	NC	NC
30	NC	NC
31	GND	Ground
32	GND	Ground
33	GND	Ground
34	NC	NC
35	ADJ	Adjust for LED brightness
36	LED-EN	LED Enable pin(+3V Input)
37	NC	NC
38	V _{LED}	Power Supply for LED(V _{LED} =5V ~ 21V)
39	V _{LED}	Power Supply for LED(V _{LED} =5V ~ 21V)
40	V _{LED}	Power Supply for LED(V _{LED} =5V ~ 21V)

5. INTERFACE TIMING CHART

(1)(a). LVDS input time sequence

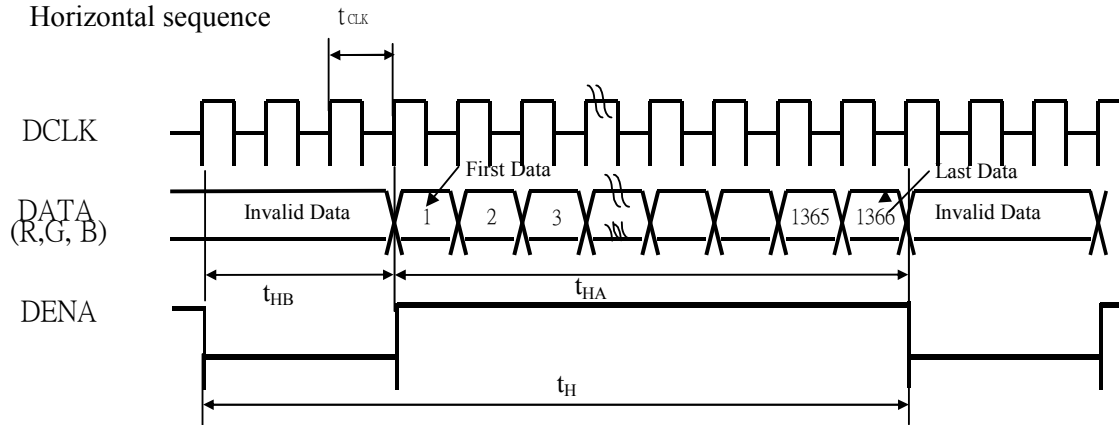

(b) LCD input time sequence

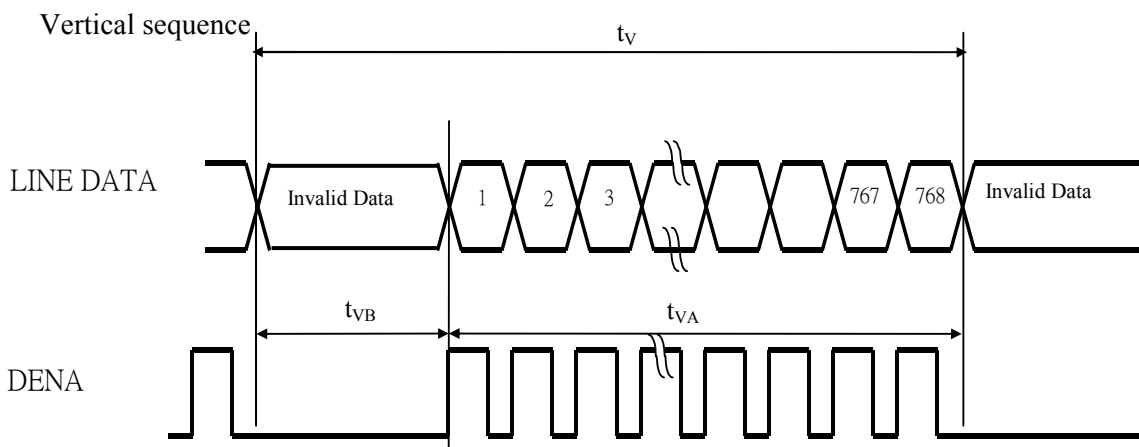

(2) Timing Chart

ITEM		SYMBOL	MIN	TYP	MAX	UNIT		
LCD Timing	Frame Rate		-	60		Hz		
	DCLK	Frequency	f_{CLK}	65.6	69.3	77.0	MHz	
		Period	t_{CLK}	13.0	14.3	16.2	ns	
	DENA	Horizontal	Horizontal total time	t_H	1410	1433	1530	t_{CLK}
			Horizontal Active time	t_{HA}	1366			t_{CLK}
			Horizontal Blank time	t_{HB}	44	67	164	t_{CLK}
	DENA	Vertical	Vertical total time	t_v	775	806	840	t_H
			Vertical Active time	t_{vA}	768			t_H
			Vertical Blank time	t_{vB}	7	38	72	t_H

【Note】

- *1) DENA (DATA ENABLE) usually is positive.
- *2) During the whole blank period, DCLK should keep input.

(3) DATA mapping

Color	Input Data	R DATA						G DATA						B DATA					
		R5	R4	R3	R2	R1	R0	G5	G4	G3	G2	G1	G0	B5	B4	B3	B2	B1	B0
		MS B					LS B	MS B					LS B	MS B					LS B
Basic Color	Black	0	0	0	0	0	0	0	0	0	0	0	0	0	0	0	0	0	0
	Red(63)	1	1	1	1	1	1	0	0	0	0	0	0	0	0	0	0	0	0
	Green(63)	0	0	0	0	0	0	1	1	1	1	1	1	0	0	0	0	0	0
	Blue(63)	0	0	0	0	0	0	0	0	0	0	0	0	1	1	1	1	1	1
	Cyan	0	0	0	0	0	0	1	1	1	1	1	1	1	1	1	1	1	1
	Magenta	1	1	1	1	1	1	0	0	0	0	0	0	1	1	1	1	1	1
	Yellow	1	1	1	1	1	1	1	1	1	1	1	1	0	0	0	0	0	0
	White	1	1	1	1	1	1	1	1	1	1	1	1	1	1	1	1	1	1
RED	RED(0)	0	0	0	0	0	0	0	0	0	0	0	0	0	0	0	0	0	0
	RED(1)	0	0	0	0	0	1	0	0	0	0	0	0	0	0	0	0	0	0
	RED(2)	0	0	0	0	1	0	0	0	0	0	0	0	0	0	0	0	0	0
	RED(62)	1	1	1	1	1	0	0	0	0	0	0	0	0	0	0	0	0	0
	RED(63)	1	1	1	1	1	1	0	0	0	0	0	0	0	0	0	0	0	0
Green	Green(0)	0	0	0	0	0	0	0	0	0	0	0	0	0	0	0	0	0	0
	Green(1)	0	0	0	0	0	0	0	0	0	0	0	1	0	0	0	0	0	0
	Green(2)	0	0	0	0	0	0	0	0	0	0	1	0	0	0	0	0	0	0
	Green(62)	0	0	0	0	0	0	1	1	1	1	1	0	0	0	0	0	0	0
	Green(63)	0	0	0	0	0	0	1	1	1	1	1	1	0	0	0	0	0	0
Blue	Blue(0)	0	0	0	0	0	0	0	0	0	0	0	0	0	0	0	0	0	0
	Blue(1)	0	0	0	0	0	0	0	0	0	0	0	0	0	0	0	0	0	1
	Blue(2)	0	0	0	0	0	0	0	0	0	0	0	0	0	0	0	0	1	0
	Blue(62)	0	0	0	0	0	0	0	0	0	0	0	0	1	1	1	1	1	0
	Blue(63)	0	0	0	0	0	0	0	0	0	0	0	0	1	1	1	1	1	1

【Note】

- 1) Gray level:
Color(n) : n is level order; higher n means brighter level.
- 2) DATA:
1: high , 0: low

6. BLOCK DIAGRAM

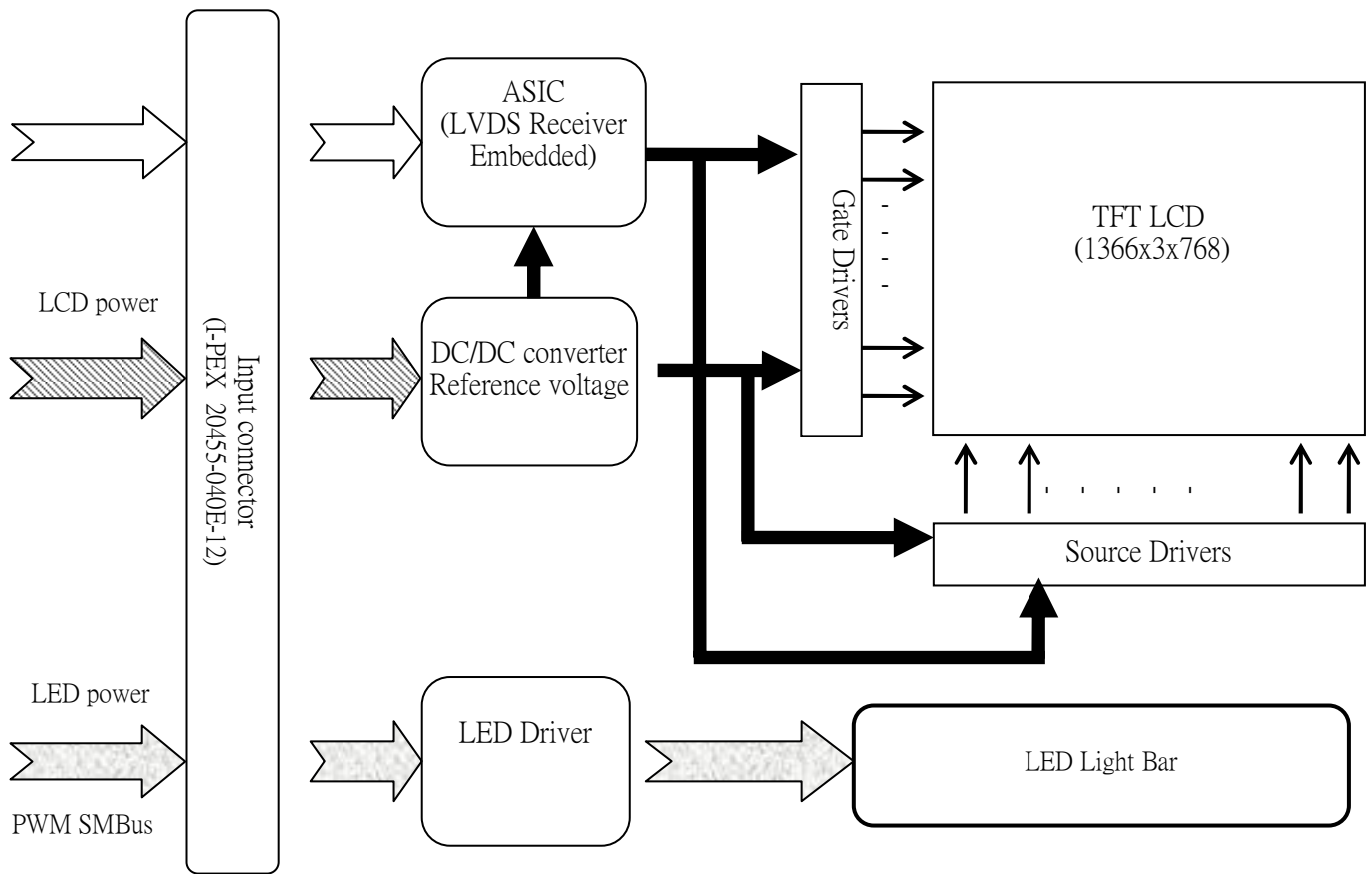

7. MECHANICAL SPECIFICATION

(1) Front side

The tolerance, not show in the figure, is $\pm 0.5\text{mm}$.

[Unit : mm]

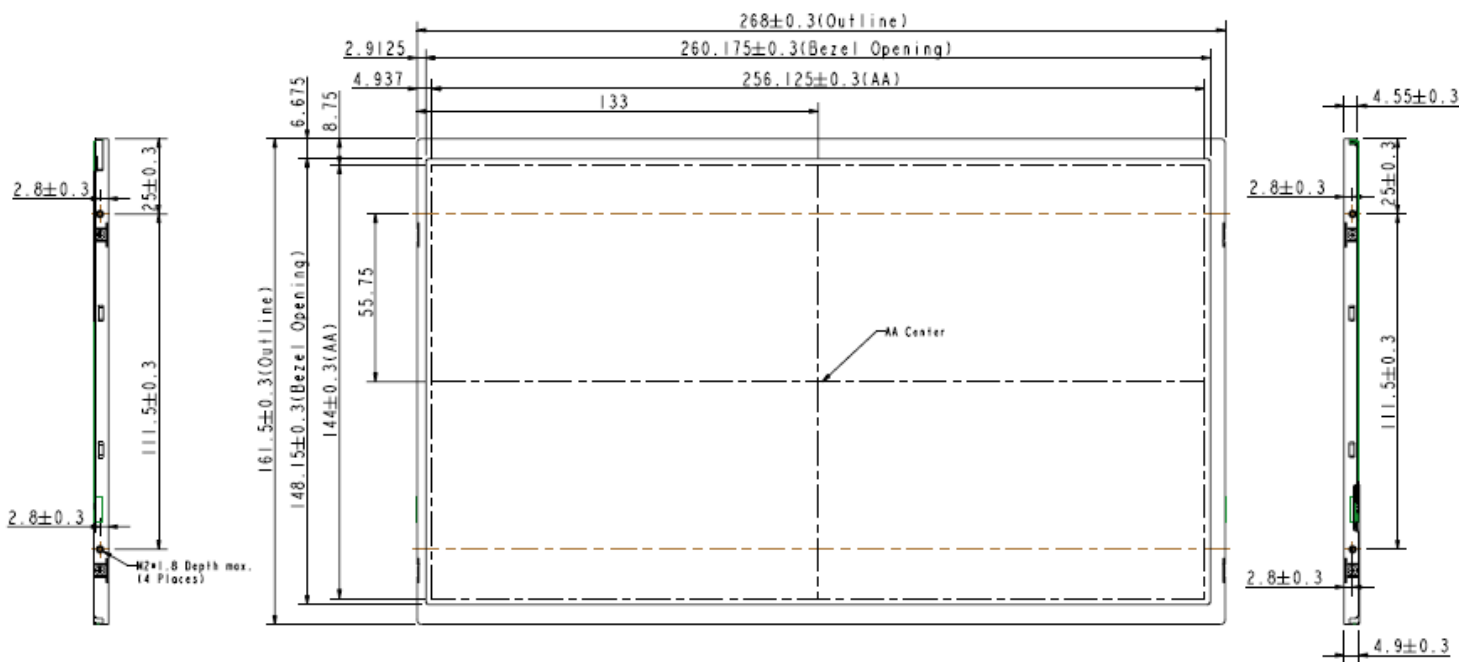

2) Rear side

The tolerance, not show in the figure, is $\pm 0.5\text{mm}$.

[Unit : mm]

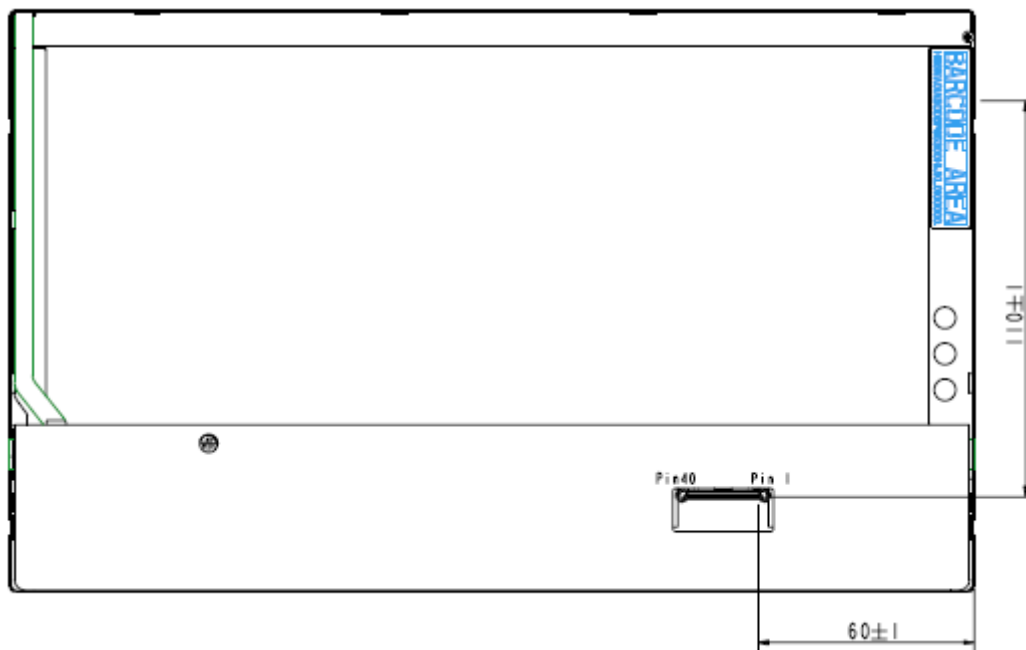

8. OPTICAL CHARACTERISTICS

Ta=25°C · VDD=3.3V

ITEM	SYMBOL	CONDITION	MIN.	TYP.	MAX.	UNIT	NOTE	
Contrast Ratio	CR	Point-7		400	-	--	*1) 2)	
Luminance (5P)	L	5-Point Avg.	TBD	200	-	cd/m ²	*1) 3)	
Uniformity(5P)	ΔL	θ=ψ= 0°	80	-	-	%	*1) 3)	
Response Time	Tr	θ=ψ= 0°	-	10	16	ms	*5)	
Cross talk	CT	θ=ψ= 0°	-	-	-	%	*6)	
View angle	Horizontal	Ψ	CR ≥ 10	45/-45	-	-	°	*4)
	Vertical	θ		15/-30	-	-	°	*4)
Color Temperature Coordinate	W	X	θ=ψ= 0°	0.293	0.313	0.333	*3)	
		Y		0.309	0.329	0.349		
	R	X		0.550	0.580	0.610		
		Y		0.310	0.340	0.370		
	G	X		0.280	0.310	0.340		
		Y		0.520	0.550	0.580		
	B	X		0.125	0.155	0.185		
		Y		0.125	0.155	0.185		
Gamut		θ=ψ= 0°	42%	45%				
Gamma	γ	GL	2.0	2.2	2.4		*7)	

Color coordinate and color gamut are measured by SRUL1R, response time is measured by TRD-100, and all the other items are measured by BM-5A (TOPCON). All these items are measured under the dark room condition (no ambient light).

Measurement Condition: IL=18mA(each LED)

Definition of these measurement items is as follows:

*1) Setup of Measurement Equipment

The LCD module should be turn-on to a stable luminance level to be reached. The measurement should be executed after lighting Backlight for 20 minutes and in a dark room.

*2) Definition of Contrast Ratio

CR=ON (White) Luminance/OFF (Black) Luminance

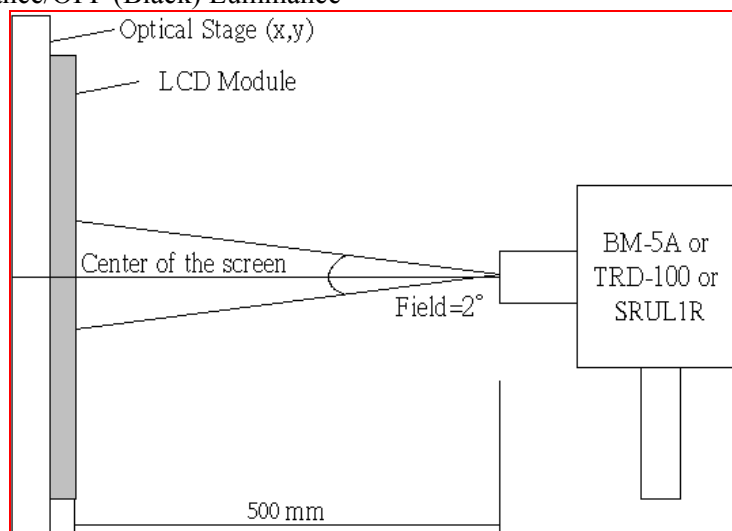

***3) Definition of Luminance and Luminance uniformity**

Central luminance: The white luminance is measured at the center position “5” on the screen, see Fig.1 below.

5P Luminance (AVG): The white luminance is measured at measuring points 5、10、11、12、13, see Fig.1 below.

$$\Delta L = Lw(\text{Min})_{5\text{points}} \div Lw(\text{Max})_{5\text{points}}$$

$$\Delta L = Lw(\text{Min})_{13\text{points}} \div Lw(\text{Max})_{13\text{points}}$$

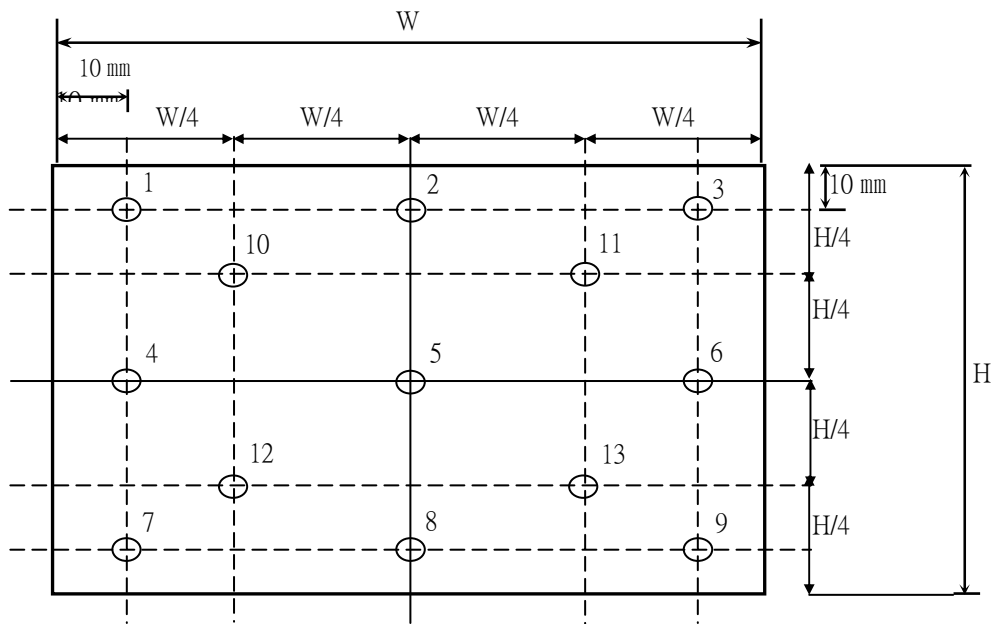
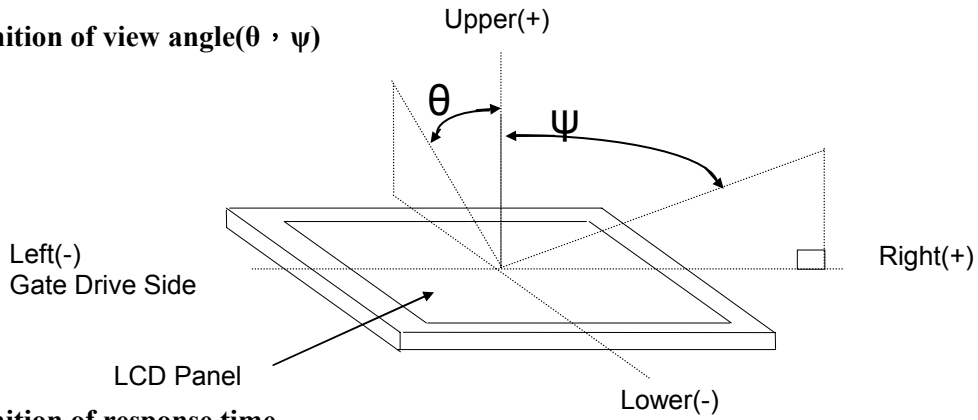
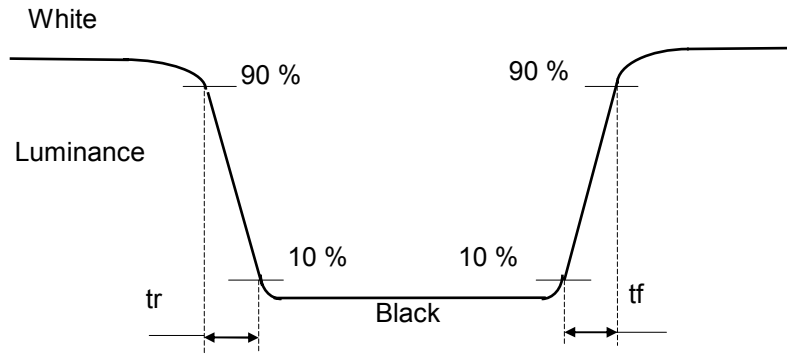

Fig.1 Measure point (Active area)

***4) Definition of view angle(θ , ψ)**



***5) Definition of response time**



***6) Crosstalk Modulation Ratio:**

$$CT = | Y_B - Y_A | / Y_A \times 100\%$$

Y_A 、 Y_B measure position and definition

Y_A means luminance at gray level 32(exclude gray level 0 pattern)

Y_B means luminance at gray level 32(include gray level 0 pattern)

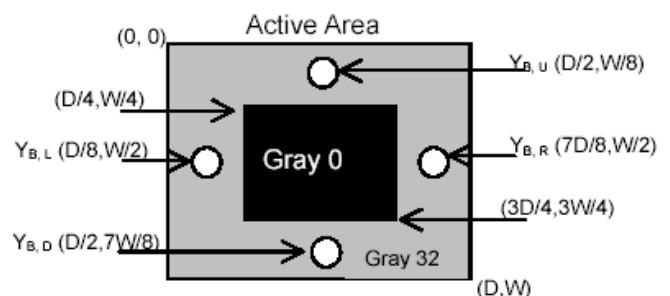
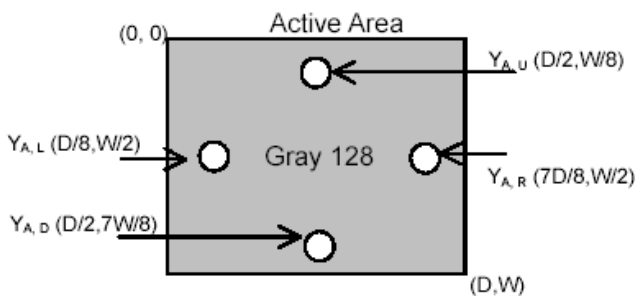
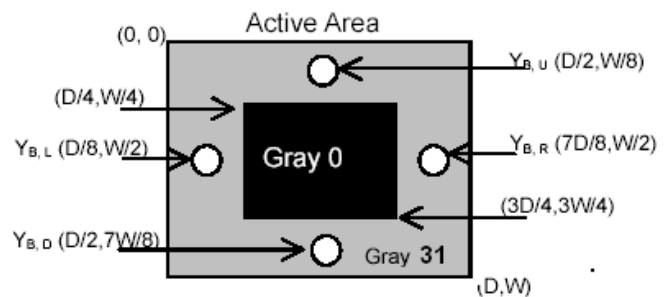
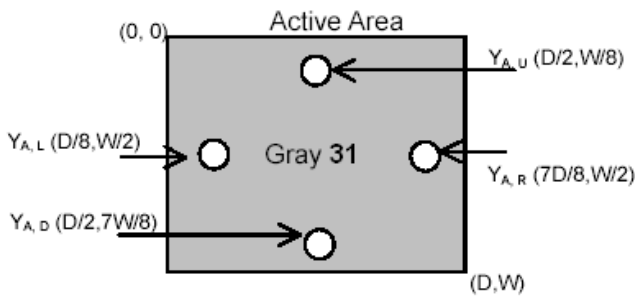

***7) Definition Gamma (VESA)**

Based on Customer Sample, take the average value as a standard center value and the variation range of gamma value caused by loop voltage error should be between +/- 0.2. the bellow figure shows how to obtain the gamma curve and γ (from gray level: 0 、 4 、 8-----60 、 63).

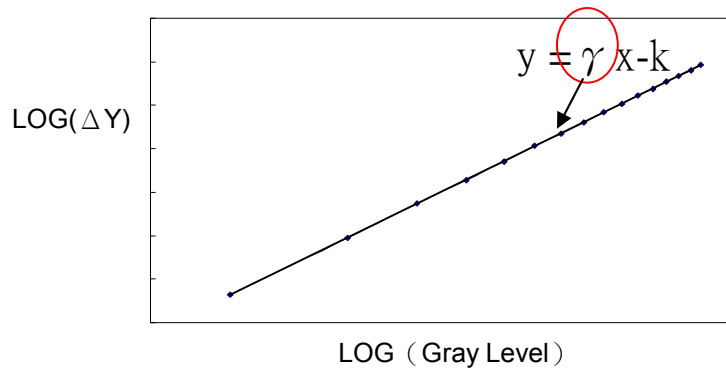

9. RELIABILITY TEST CONDITIONS

(A) Temperature and humidity

TEST ITEMS	CONDITIONS	NOTE
Low Temperature Storage	-30° C ; 250Hrs	
High Temperature Storage	65° C ; 250Hrs	
Low Temperature Operation	0° C ; 250Hrs	
High Temperature Operation	50° C ; 250Hrs	
High Temperature High Humidity Operation	40° C ; 95%RH MAX ; 250Hrs	
Thermal Shock	-40° C (0.5Hr) ~ 65° C (0.5 Hr) , Ramp < 20° C, 100 Cycles	

(B) Shock and Vibration

TEST ITEMS	CONDITIONS
Shock	250G 、 2ms(half sin wave) 、 ± X 、 ± Y 、 ± Z one time in each axis
Vibration	1.5G 、 5~500Hz 、 0.5 Octave/min 、 1Hr in each +/-X 、 +/-Y 、 +/-Z

(C) ESD

ITEM	CONDITION	NOTE
ESD	200 pF , 0Ω , ±200V (Contact mode)	*1)
	150 pF , 330Ω , ±8 & 15KV (Air mode)	*2)

. 【Note】

*1) LCD glass and metal bezel

*2) IF connector pins

(D) Judgment Standard

The Judgment of the above test should be made as follow:

Pass: Normal display image with no obvious non-uniformity and no line defect. Partial transformation of the module parts should be ignored.

Fail: No display image, obvious non-uniform, or line defect.