

TFT LCD Preliminary Specification

MODEL NO.: M236H3- LA2

Customer: _____ Approved by: _____ Note:
--

核准時間	部門	審核	角色	投票
2010-02-23 08:46:14	MTR 產品管理處		Director	Accept

- CONTENTS -

REVISION HISTORY	3
1. GENERAL DESCRIPTION	4
1.1 OVERVIEW	
1.2 FEATURES	
1.3 APPLICATION	
1.4 GENERAL SPECIFICATIONS	
1.5 MECHANICAL SPECIFICATIONS	
2. ABSOLUTE MAXIMUM RATINGS	5
2.1 ABSOLUTE RATINGS OF ENVIRONMENT	
2.2 ELECTRICAL ABSOLUTE RATINGS	
2.2.1 TFT LCD MODULE	
2.2.2 BACKLIGHT UNIT	
3. ELECTRICAL CHARACTERISTICS	7
3.1 TFT LCD MODULE	
3.1.1 Vcc POWER DIP CONDITION	
3.2 BACKLIGHT UNIT	
3.3 LIGHTBAR CONNECTOR PIN ASSIGNMENT	
4. BLOCK DIAGRAM	11
4.1 TFT LCD MODULE	
5. INPUT TERMINAL PIN ASSIGNMENT	12
5.1 TFT LCD MODULE	
5.2 LVDS DATA MAPPING TABLE	
5.3 COLOR DATA INPUT ASSIGNMENT	
6. INTERFACE TIMING	15
6.1 INPUT SIGNAL TIMING SPECIFICATIONS	
6.2 POWER ON/OFF SEQUENCE	
7. OPTICAL CHARACTERISTICS	18
7.1 TEST CONDITIONS	
7.2 OPTICAL SPECIFICATIONS	
8. PACKAGING	22
8.1 PACKING SPECIFICATIONS	
8.2 PACKING METHOD	
9. DEFINITION OF LABELS	24
10. RELIABILITY TEST	26
11. PRECAUTIONS	27
11.1 ASSEMBLY AND HANDLING PRECAUTIONS	
11.2 SAFETY PRECAUTIONS	
11.3 SAFETY STANDARDS	
11.4 STORAGE	
11.5 OPERATION CONDITION GUIDE	
11.6 OTHER	
12. MECHANICAL CHARACTERISTICS	29



REVISION HISTORY

Version	Date	Section	Description
Ver 1.0	10, Feb, 10'	-	M236H3 -LA2 Preliminary specification was first issued.

1. GENERAL DESCRIPTION

1.1 OVERVIEW

M236H3-LA2 is a 23.6" TFT Liquid Crystal Display module with WLED Backlight unit and 30 pins 2ch-LVDS interface. This module supports 1920 x 1080 Full HD mode and can display up to 16.7M colors. The converter module for Backlight is not built in.

1.2 FEATURES

- Extra-wide viewing angle.
- High contrast ratio.
- Fast response time.
- Full HD (1920 x 1080 pixels) resolution.
- DE (Data Enable) only mode.
- LVDS (Low Voltage Differential Signaling) interface.
- RoHS compliance.

1.3 APPLICATION

- TFT LCD Monitor

1.4 GENERAL SPECIFICATIONS

Item	Specification	Unit	Note
Active Area	521.28(H) x 293.22(V) (23.547" real diagonal)	mm	(1)
Bezel Opening Area	525.22 (H) x 297.22 (V)	mm	
Driver Element	a-Si TFT active matrix	-	-
Pixel Number	1920 x R.G.B. x 1080	pixel	-
Pixel Pitch	0.2715 (H) x 0.2715 (V)	mm	-
Pixel Arrangement	RGB vertical stripe	-	-
Display Colors	16.7M	color	-
Transmissive Mode	Normally White	-	-
Surface Treatment	AG type, 3H hard coating, Haze 25	-	-
Module Power Consumption	17.8	Watt	(2)

1.5 MECHANICAL SPECIFICATIONS

Item	Min.	Typ.	Max.	Unit	Note	
Module Size	Horizontal(H)	544.3	544.8	545.3	mm	(1)
	Vertical(V)	320.0	320.5	321.0	mm	
	Depth(D)	10.9	11.4	11.9	mm	
Weight	-	2450	2500	g	-	

Note (1) Please refer to the attached drawings for more information of front and back outline dimensions.

Note (2) Please refer to sec.3.1 & 3.2 for more information of power consumption

2. ABSOLUTE MAXIMUM RATINGS

2.1 ABSOLUTE RATINGS OF ENVIRONMENT

Item	Symbol	Value		Unit	Note
		Min.	Max.		
Storage Temperature	T _{ST}	-20	60	°C	(1)
Operating Ambient Temperature	T _{OP}	0	50	°C	(1), (2)
Shock (Non-Operating)	S _{NOP}	-	50	G	(3), (5)
Vibration (Non-Operating)	V _{NOP}	-	1.5	G	(4), (5)

Note (1) Temperature and relative humidity range is shown in the figure below.

- (a) 90 %RH Max. (Ta = 40 °C).
- (b) Wet-bulb temperature should be 39 °C Max. (Ta > 40 °C).
- (c) No condensation.

Note (2) The temperature of panel display surface area should be 0 °C Min. and 60 °C Max

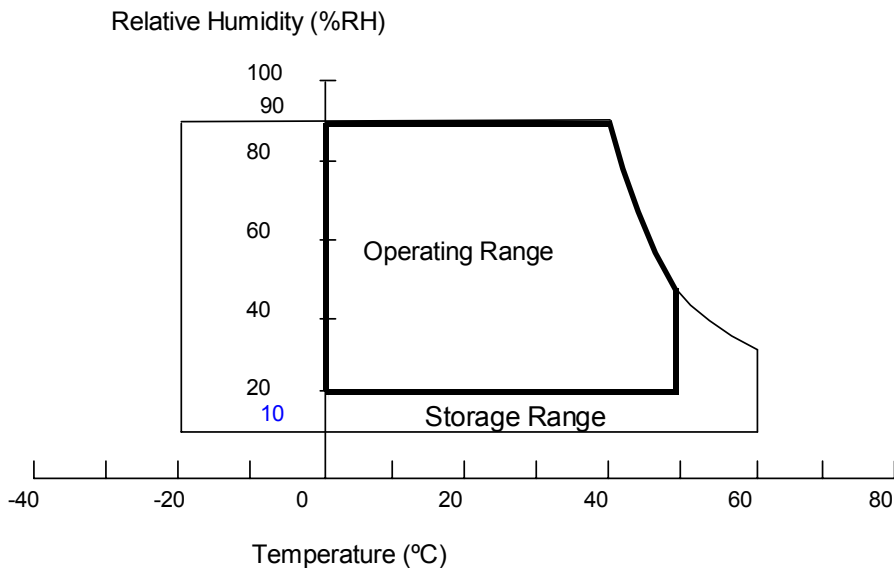

Note (3) 11ms, half sine wave, 1 time for ± X, ± Y, ± Z.

Note (4) 10 ~ 300 Hz, 10min/cycle, 3 cycles each X, Y, Z.

Note (5) At testing Vibration and Shock, the fixture in holding the module has to be hard and rigid enough so that the module would not be twisted or bent by the fixture.

The fixing condition is shown as below:

At Room Temperature

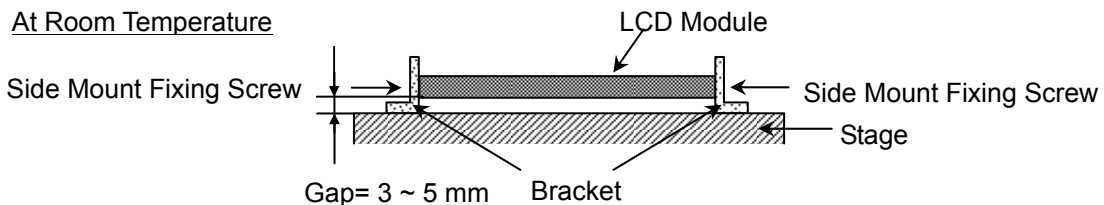

2.2 ELECTRICAL ABSOLUTE RATINGS

2.2.1 TFT LCD MODULE

Item	Symbol	Value		Unit	Note
		Min.	Max.		
Power Supply Voltage	V _{CC}	-0.3	+6.0	V	(1)
Logic Input voltage	V _{logic}	-0.3	3.6		

2.2.2 BACKLIGHT UNIT

Item	Symbol	Value			Unit	Note
		Min.	Typ	Max.		
LED Forward Current Per Input Pin	I _F	0	40	50	mA	(1), (2) Duty=100%
LED Reverse Voltage Per Input Pin	V _R	---	---	60	V	
LED Pulse Forward Current Per Input Pin	I _P	---	---	160	mA	(1), (2) Pulse Width 10msec. and Duty 10%

Note (1) Permanent damage to the device may occur if maximum values are exceeded. Function operation should be restricted to the conditions described under Normal Operating Conditions.

Note (2) Specified values are for input pin of LED light bar at Ta=25±2 (Refer to 3.2 and 3.3 for further information).

3. ELECTRICAL CHARACTERISTICS

3.1 TFT LCD MODULE

Ta = 25 ± 2 °C

Parameter	Symbol	Value			Unit	Note
		Min.	Typ.	Max.		
Power Supply Voltage	V _{CC}	4.5	5.0	5.5	V	-
Ripple Voltage	V _{RP}	-	-	100	mV	-
Rush Current	I _{RUSH}			3	A	(2)
Power Supply Current	White		0.5	0.6	A	(3a)
	Black		1.1	1.32	A	(3b)
	Vertical Stripe		0.9	1.08	A	(3c)
Power Consumption	PLCD		5.5	6.6	Watt	(4)
LVDS differential input voltage	V _{id}	200	-	600	mV	
LVDS common input voltage	V _{ic}	1.0	1.2	1.4	V	
Logic High Input Voltage	V _{IH}	2.64	-	3.6	V	
Logic Low Input Voltage	V _{IL}	0	-	0.66	V	

Note (1) The module should be always operated within above ranges.

Note (2) Measurement Conditions:

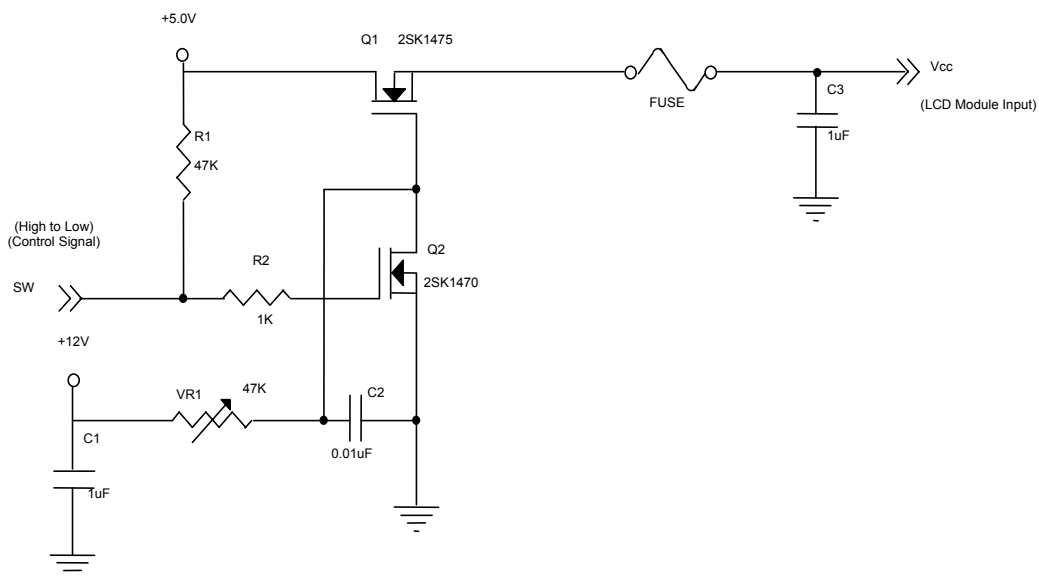

Vcc rising time is 470μs

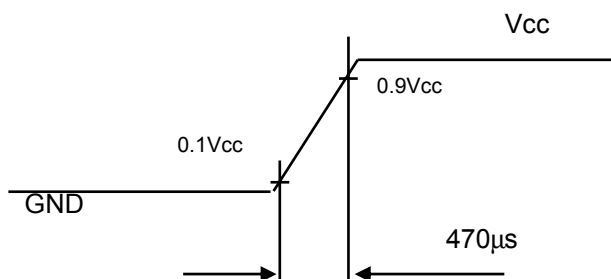

Note (3) The specified power supply current is under the conditions at $V_{CC} = 5.0\text{ V}$, $T_a = 25 \pm 2\text{ }^\circ\text{C}$, $F_r = 60\text{ Hz}$, whereas a power dissipation check pattern below is displayed.

a. White Pattern



Active Area

b. Black Pattern



Active Area

c. Vertical Stripe Pattern

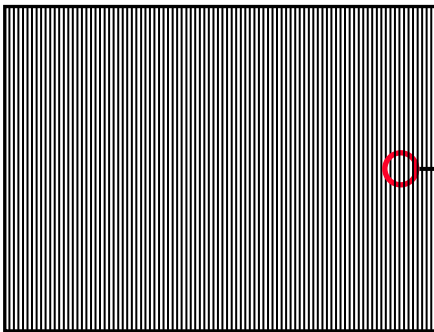

Active Area

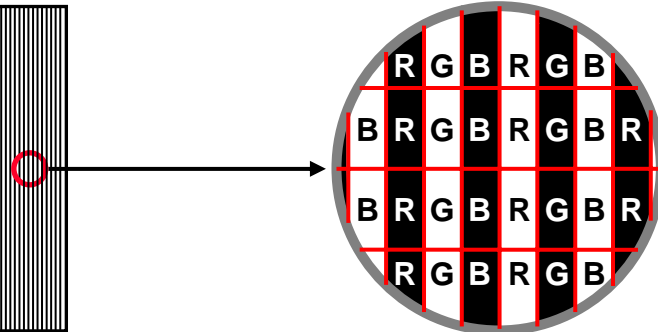

Note (4) The power consumption is specified at the pattern with the maximum current

Note (5) VID waveform condition

Single-End

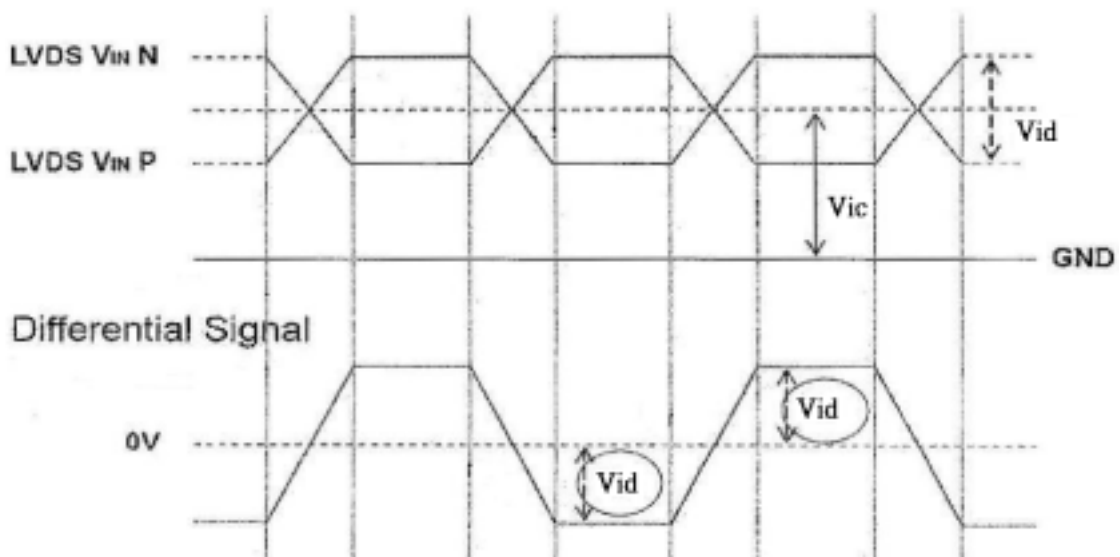

3.1.1 Vcc Power Dip Condition:

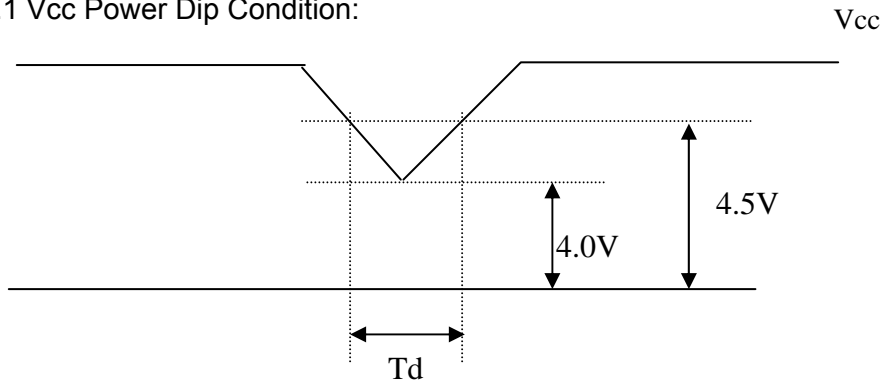
 Dip condition: $4.0V \leq V_{cc} \leq 4.5V, T_d \leq 20ms$

3.2 BACKLIGHT UNIT (LED matrix is 12S8P)

 $T_a = 25 \pm 2 \text{ } ^\circ\text{C}$

Parameter	Symbol	Value			Unit	Note
		Min.	Typ.	Max.		
LED Light Bar Input Voltage Per Input Pin	V_{PIN}	34	38.4	42	V	(1), Duty=100%, $I_{PIN}=40mA$
LED Light Bar Current Per Input Pin	I_{PIN}	0	40	50	mA	(1), (2) Duty=100%
LED Life Time	L_{LED}	15000	30000		Hrs	(3)
Power Consumption	P_{BL}	---	12.3	13.5	W	(1) Duty=100%, $I_{PIN}=40mA$

Note (1) LED light bar input voltage and current are measured by utilizing a true RMS multimeter as shown below:

Note (2) $P_{BL} = I_{PIN} \times V_{PIN} \times (8)$ input pins, LED light bar circuit is (12)Series, (8)Parallel.

Note (3) The lifetime of LED is defined as the time when LED packages continue to operate under the conditions at $T_a = 25 \pm 2$ and $I = (20)mA$ (per chip) until the brightness becomes 50% of its original value.

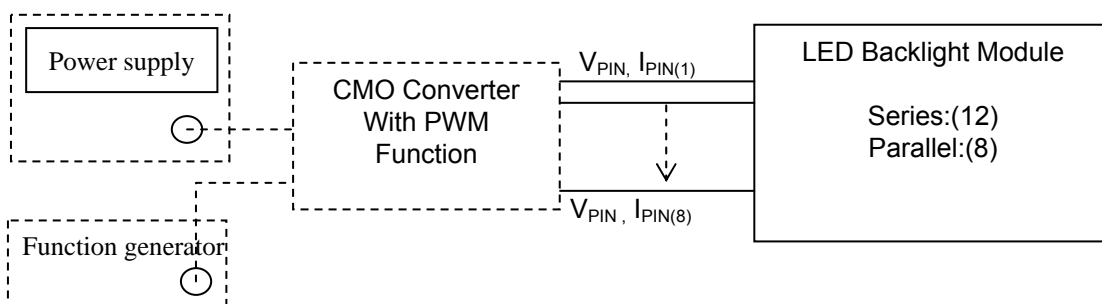

3.3 LIGHTBAR Connector Pin Assignment

Connector: 7083K-F12N-00L , (Entry) or Compatible

CN1

Pin number	Description
1	Cathode of LED string
2	Cathode of LED string
3	Cathode of LED string
4	Cathode of LED string
5	Not connection, this pin should be open
6	VLED
7	VLED
8	Not connection, this pin should be open
9	Cathode of LED string
10	Cathode of LED string
11	Cathode of LED string
12	Cathode of LED string

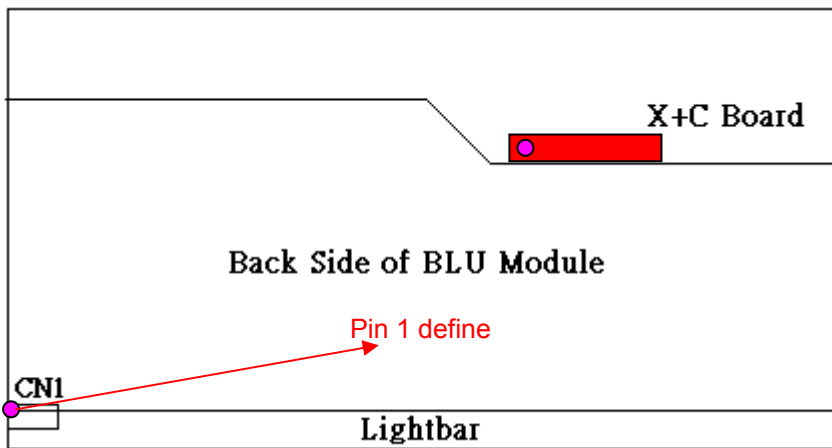

4. BLOCK DIAGRAM

4.1 TFT LCD MODULE

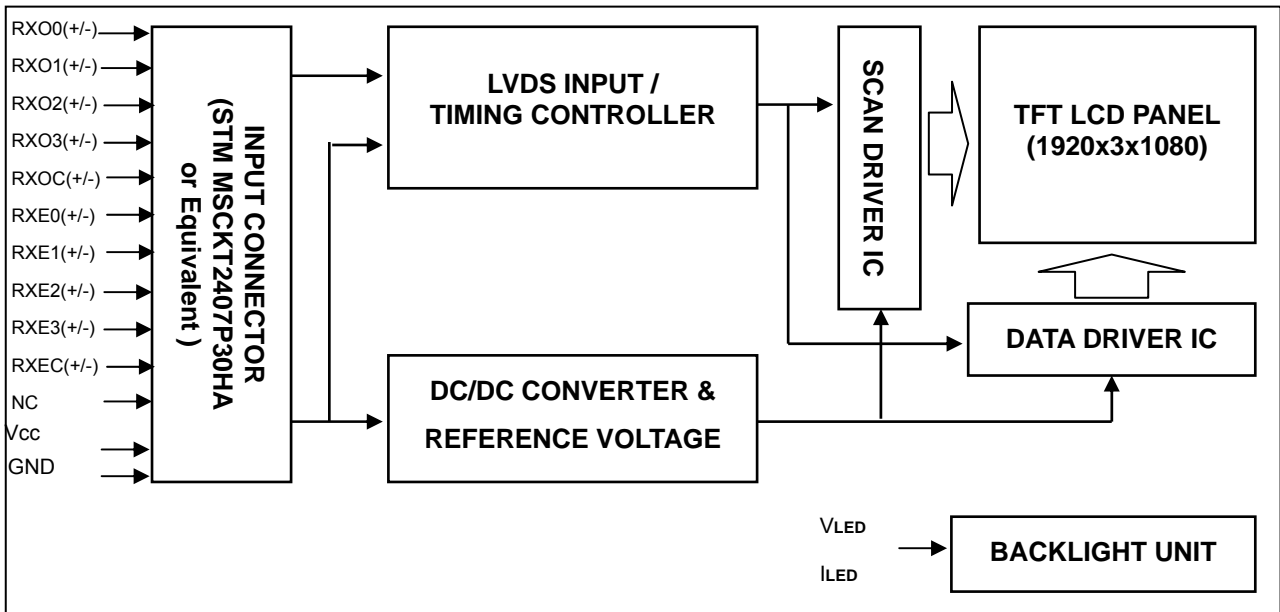

5. INPUT TERMINAL PIN ASSIGNMENT

5.1 TFT LCD MODULE

Pin	Name	Description
1	RXO0-	Negative LVDS differential data input. Channel O0 (odd)
2	RXO0+	Positive LVDS differential data input. Channel O0 (odd)
3	RXO1-	Negative LVDS differential data input. Channel O1 (odd)
4	RXO1+	Positive LVDS differential data input. Channel O1 (odd)
5	RXO2-	Negative LVDS differential data input. Channel O2 (odd)
6	RXO2+	Positive LVDS differential data input. Channel O2 (odd)
7	GND	Ground
8	RXOC-	Negative LVDS differential clock input. (odd)
9	RXOC+	Positive LVDS differential clock input. (odd)
10	RXO3-	Negative LVDS differential data input. Channel O3(odd)
11	RXO3+	Positive LVDS differential data input. Channel O3 (odd)
12	RXE0-	Negative LVDS differential data input. Channel E0 (even)
13	RXE0+	Positive LVDS differential data input. Channel E0 (even)
14	GND	Ground
15	RXE1-	Negative LVDS differential data input. Channel E1 (even)
16	RXE1+	Positive LVDS differential data input. Channel E1 (even)
17	GND	Ground
18	RXE2-	Negative LVDS differential data input. Channel E2 (even)
19	RXE2+	Positive LVDS differential data input. Channel E2 (even)
20	RXEC-	Negative LVDS differential clock input. (even)
21	RXEC+	Positive LVDS differential clock input. (even)
22	RXE3-	Negative LVDS differential data input. Channel E3 (even)
23	RXE3+	Positive LVDS differential data input. Channel E3 (even)
24	GND	Ground
25	NC	For LCD internal use only, Do not connect
26	NC	For LCD internal use only, Do not connect
27	NC	For LCD internal use only, Do not connect
28	Vcc	+5.0V power supply
29	Vcc	+5.0V power supply
30	Vcc	+5.0V power supply

Note (1) Connector Part No.: STM, MSCKT2407P30HA or Equivalent

Note (2) Mating Wire Cable Connector Part No.: FI-X30H(JAE) or FI-X30HL(JAE).

Note (3) Mating FFC Cable Connector Part No.: 217007-013001 (P-TWO) or JF05X030-1 (JAE).

Note (4) The first pixel is odd.

Note (5) Input signal of even and odd clock should be the same timing.

5.2 LVDS DATA MAPPING TABLE

LVDS Channel O0	LVDS output	D7	D6	D4	D3	D2	D1	D0
	Data order	OG0	OR5	OR4	OR3	OR2	OR1	OR0
LVDS Channel O1	LVDS output	D18	D15	D14	D13	D12	D9	D8
	Data order	OB1	OB0	OG5	OG4	OG3	OG2	OG1
LVDS Channel O2	LVDS output	D26	D25	D24	D22	D21	D20	D19
	Data order	DE	NA	NA	OB5	OB4	OB3	OB2
LVDS Channel O3	LVDS output	D23	D17	D16	D11	D10	D5	D27
	Data order	NA	OB7	OB6	OG7	OG6	OR7	OR6
LVDS Channel E0	LVDS output	D7	D6	D4	D3	D2	D1	D0
	Data order	EG0	ER5	ER4	ER3	ER2	ER1	ER0
LVDS Channel E1	LVDS output	D18	D15	D14	D13	D12	D9	D8
	Data order	EB1	EB0	EG5	EG4	EG3	EG2	EG1
LVDS Channel E2	LVDS output	D26	D25	D24	D22	D21	D20	D19
	Data order	DE	NA	NA	EB5	EB4	EB3	EB2
LVDS Channel E3	LVDS output	D23	D17	D16	D11	D10	D5	D27
	Data order	NA	EB7	EB6	EG7	EG6	ER7	ER6

5.3 COLOR DATA INPUT ASSIGNMENT

The brightness of each primary color (red, green and blue) is based on the 8-bit gray scale data input for the color. The higher the binary input, the brighter the color. The table below provides the assignment of color versus data input.

Color		Data Signal																							
		Red								Green								Blue							
		R7	R6	R5	R4	R3	R2	R1	R0	G7	G6	G5	G4	G3	G2	G1	G0	B7	B6	B5	B4	B3	B2	B1	B0
Basic Colors	Black	0	0	0	0	0	0	0	0	0	0	0	0	0	0	0	0	0	0	0	0	0	0	0	0
	Red	1	1	1	1	1	1	1	1	0	0	0	0	0	0	0	0	0	0	0	0	0	0	0	0
	Green	0	0	0	0	0	0	0	0	1	1	1	1	1	1	1	1	0	0	0	0	0	0	0	0
	Blue	0	0	0	0	0	0	0	0	0	0	0	0	0	0	0	0	1	1	1	1	1	1	1	1
	Cyan	0	0	0	0	0	0	0	0	1	1	1	1	1	1	1	1	1	1	1	1	1	1	1	1
	Magenta	1	1	1	1	1	1	1	1	0	0	0	0	0	0	0	0	1	1	1	1	1	1	1	1
	Yellow	1	1	1	1	1	1	1	1	1	1	1	1	1	1	1	1	0	0	0	0	0	0	0	0
	White	1	1	1	1	1	1	1	1	1	1	1	1	1	1	1	1	1	1	1	1	1	1	1	1
Gray Scale Of Red	Red(0) / Dark	0	0	0	0	0	0	0	0	0	0	0	0	0	0	0	0	0	0	0	0	0	0	0	
	Red(1)	0	0	0	0	0	0	0	1	0	0	0	0	0	0	0	0	0	0	0	0	0	0	0	
	Red(2)	0	0	0	0	0	0	1	0	0	0	0	0	0	0	0	0	0	0	0	0	0	0	0	
	:	:	:	:	:	:	:	:	:	:	:	:	:	:	:	:	:	:	:	:	:	:	:	:	
	:	:	:	:	:	:	:	:	:	:	:	:	:	:	:	:	:	:	:	:	:	:	:	:	
	:	:	:	:	:	:	:	:	:	:	:	:	:	:	:	:	:	:	:	:	:	:	:	:	
	Red(253)	1	1	1	1	1	1	0	1	0	0	0	0	0	0	0	0	0	0	0	0	0	0	0	
	Red(254)	1	1	1	1	1	1	1	0	0	0	0	0	0	0	0	0	0	0	0	0	0	0	0	
Red(255)	1	1	1	1	1	1	1	1	0	0	0	0	0	0	0	0	0	0	0	0	0	0	0		
Gray Scale Of Green	Green(0) / Dark	0	0	0	0	0	0	0	0	0	0	0	0	0	0	0	0	0	0	0	0	0	0	0	
	Green(1)	0	0	0	0	0	0	0	0	0	0	0	0	0	0	1	0	0	0	0	0	0	0	0	
	Green(2)	0	0	0	0	0	0	0	0	0	0	0	0	0	1	0	0	0	0	0	0	0	0	0	
	:	:	:	:	:	:	:	:	:	:	:	:	:	:	:	:	:	:	:	:	:	:	:	:	
	:	:	:	:	:	:	:	:	:	:	:	:	:	:	:	:	:	:	:	:	:	:	:	:	
	:	:	:	:	:	:	:	:	:	:	:	:	:	:	:	:	:	:	:	:	:	:	:	:	
	Green(253)	0	0	0	0	0	0	0	0	1	1	1	1	1	1	0	1	0	0	0	0	0	0	0	
	Green(254)	0	0	0	0	0	0	0	0	1	1	1	1	1	1	1	0	0	0	0	0	0	0	0	
Green(255)	0	0	0	0	0	0	0	0	1	1	1	1	1	1	1	1	0	0	0	0	0	0	0		
Gray Scale Of Blue	Blue(0) / Dark	0	0	0	0	0	0	0	0	0	0	0	0	0	0	0	0	0	0	0	0	0	0	0	
	Blue(1)	0	0	0	0	0	0	0	0	0	0	0	0	0	0	0	0	0	0	0	0	0	0	1	
	Blue(2)	0	0	0	0	0	0	0	0	0	0	0	0	0	0	0	0	0	0	0	0	0	1	0	
	:	:	:	:	:	:	:	:	:	:	:	:	:	:	:	:	:	:	:	:	:	:	:	:	
	:	:	:	:	:	:	:	:	:	:	:	:	:	:	:	:	:	:	:	:	:	:	:	:	
	:	:	:	:	:	:	:	:	:	:	:	:	:	:	:	:	:	:	:	:	:	:	:	:	
	Blue(253)	0	0	0	0	0	0	0	0	0	0	0	0	0	0	0	1	1	1	1	1	1	1	0	
	Blue(254)	0	0	0	0	0	0	0	0	0	0	0	0	0	0	0	1	1	1	1	1	1	1	0	
Blue(255)	0	0	0	0	0	0	0	0	0	0	0	0	0	0	0	1	1	1	1	1	1	1	1		

Note (1) 0: Low Level Voltage, 1: High Level Voltage

6. INTERFACE TIMING

6.1 INPUT SIGNAL TIMING SPECIFICATIONS

The input signal timing specifications are shown as the following table and timing diagram.

Signal	Item	Symbol	Min.	Typ.	Max.	Unit	Note
LVDS Clock	Frequency	F_c	58.54	74.25	98	MHz	-
	Period	T_c	-	13.47	-	ns	-
	Input cycle to cycle jitter	T_{rcj}	$-0.02 \cdot T_c$	-	$0.02 \cdot T_c$	ns	(1)
	Spread spectrum modulation range	$F_{clk_{in_mod}}$	$0.98 \cdot F_c$	-	$1.02 \cdot F_c$	MHz	(2)
	Spread spectrum modulation frequency	F_{SSM}	-	-	200	KHz	
	High Time	T_{ch}	-	4/7	-	T_c	-
	Low Time	T_{cl}	-	3/7	-	T_c	-
LVDS Data	Setup Time	T_{lvs}	600	-	-	ps	(3)
	Hold Time	T_{lvh}	600	-	-	ps	
Vertical Active Display Term	Frame Rate	F_r	50	60	75	Hz	$T_v = T_{vd} + T_{vb}$
	Total	T_v	1115	1125	1136	T_h	-
	Display	T_{vd}	1080	1080	1080	T_h	-
	Blank	T_{vb}	35	45	56	T_h	-
Horizontal Active Display Term	Total	T_h	1050	1100	1150	T_c	$T_h = T_{hd} + T_{hb}$
	Display	T_{hd}	960	960	960	T_c	-
	Blank	T_{hb}	90	140	190	T_c	-

Note: Because this module is operated by DE only mode, Hsync and Vsync input signals are ignored.

INPUT SIGNAL TIMING DIAGRAM

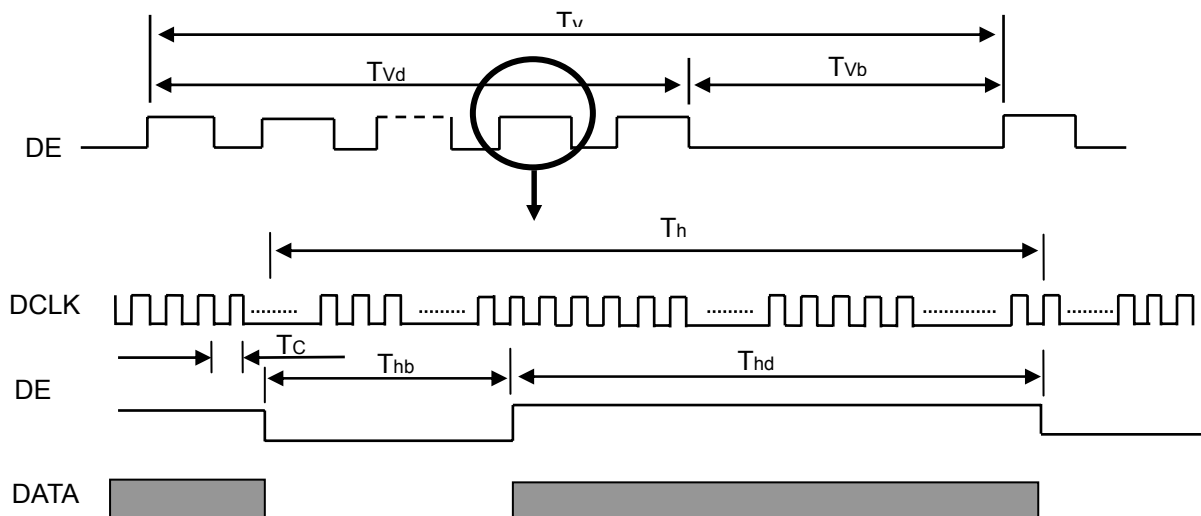

Note (1) The input clock cycle-to-cycle jitter is defined as below figures. $Trcl = |T_1 - T_1|$

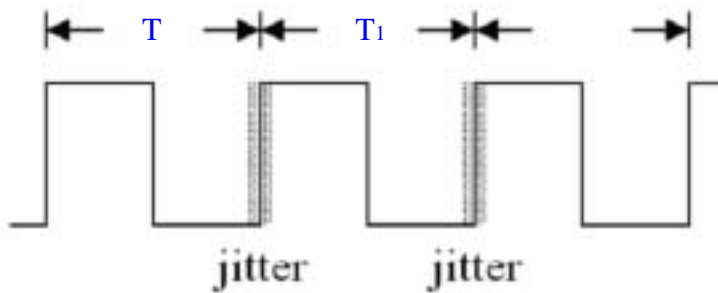

Note (2) The SSCG (Spread spectrum clock generator) is defined as below figures.

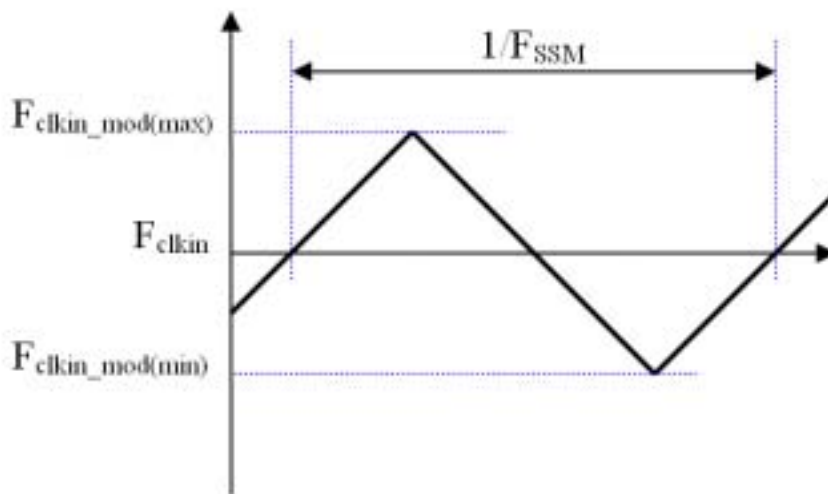

Note (3) The LVDS timing diagram and setup/hold time is defined and showing as the following figures.

LVDS RECEIVER INTERFACE TIMING DIAGRAM

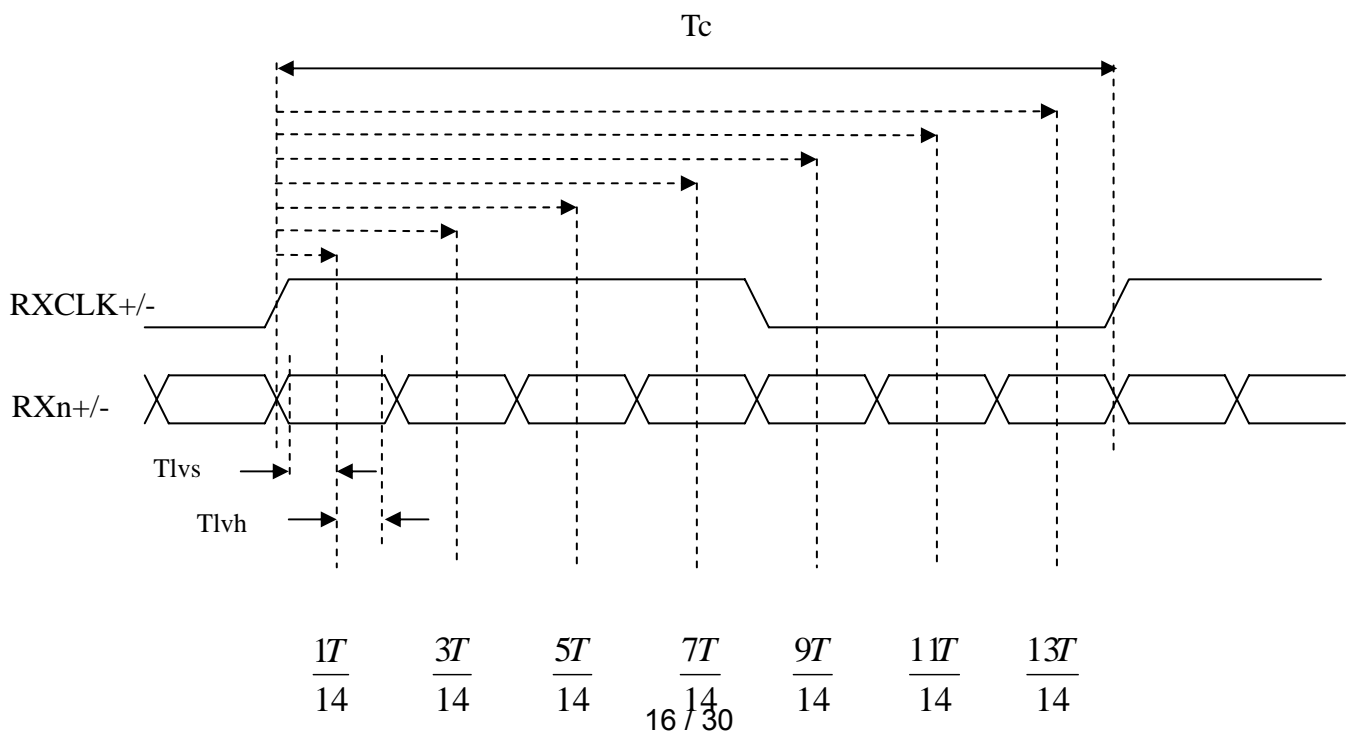

6.2 POWER ON/OFF SEQUENCE

To prevent a latch-up or DC operation of LCD module, the power on/off sequence should be as the diagram below.

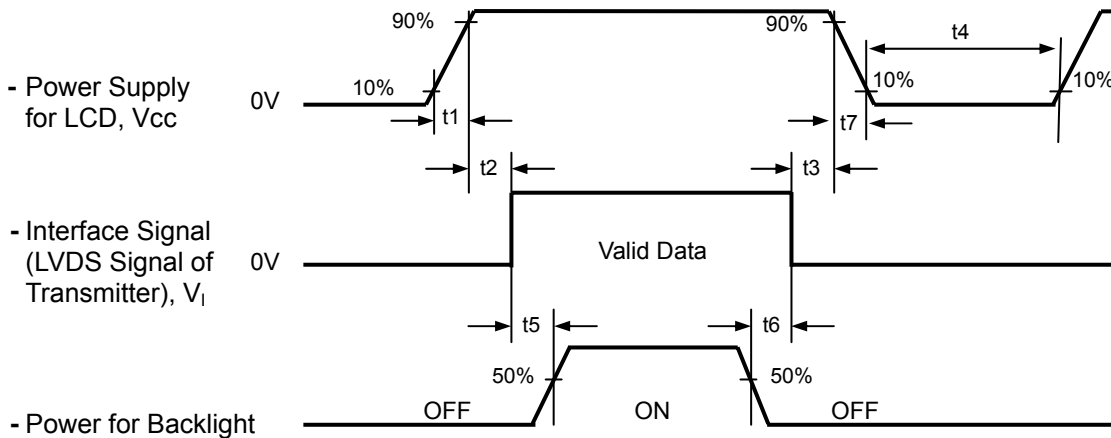

Timing Specifications:

0.5 < t ₁	10 msec
0 < t ₂	50 msec
0 < t ₃	50 msec
t ₄	500 msec
t ₅	450 msec
t ₆	90 msec
5 < t ₇	100 msec

Note.

- (1) The supply voltage of the external system for the module input should be the same as the definition of V_{cc}.
- (2) When the backlight turns on before the LCD operation of the LCD turns off, the display may momentarily become abnormal screen.
- (3) In case of V_{CC} = off level, please keep the level of input signals on the low or keep a high impedance.
- (4) T₄ should be measured after the module has been fully discharged between power off and on period.
- (5) Interface signal shall not be kept at high impedance when the power is on.
- (6) It is not guaranteed that products are damaged which is caused by not following the Power Sequence.
- (7) It is suggested that V_{cc} falling time follows t₇ specification, else slight noise is likely to occur when LCD is turned off (even backlight is already off).

7. OPTICAL CHARACTERISTICS

7.1 TEST CONDITIONS

Item	Symbol	Value	Unit
Ambient Temperature	Ta	25±2	°C
Ambient Humidity	Ha	50±10	%RH
Supply Voltage	V _{CC}	5	V
Input Signal	According to typical value in "3. ELECTRICAL CHARACTERISTICS"		
LED Light Bar Input Current Per Input Pin	I _{PIN}	40 ± 1.2	mA _{DC}
PWM Duty Ratio	D	100	%
LED Light Bar Test Converter	CMO 27-D041745		

7.2 OPTICAL SPECIFICATIONS

The relative measurement methods of optical characteristics are shown in 7.2. The following items should be measured under the test conditions described in 7.1 and stable environment shown in Note (5).

Item		Symbol	Condition	Min.	Typ.	Max.	Unit	Note
Color Chromaticity (CIE 1931)	Red	R _x	$\theta_x=0^\circ, \theta_y=0^\circ$ CS-2000	Typ - 0.03	(0.641)	Typ + 0.03	-	(1), (5)
		R _y			(0.338)			
	Green	G _x			(0.315)			
		G _y			(0.629)			
	Blue	B _x			(0.159)			
		B _y			(0.059)			
	White	W _x			(0.313)			
		W _y			(0.329)			
Center Luminance of White (Center of Screen)		L _C		250	300	-	cd/m ²	(4), (5)
Contrast Ratio		CR		700	1000	-	-	(2), (5)
Response Time		T _R	$\theta_x=0^\circ, \theta_y=0^\circ$	-	1.5	2.5	ms	(3)
		T _F		-	3.5	5.5		
White Variation		δW	$\theta_x=0^\circ, \theta_y=0^\circ$ USB2000	-	-	1.33	-	(5), (6)
Viewing Angle	Horizontal	$\theta_x- + \theta_x+$	CR 10 USB2000	150	170	-	Deg.	(1), (5)
	Vertical	$\theta_y- + \theta_y+$	USB2000	140	160	-		
Viewing Angle	Horizontal	$\theta_x- + \theta_x+$	CR 5 USB2000	160	178	---	Deg.	(1), (5)
	Vertical	$\theta_y- + \theta_y+$	USB2000	150	170	---		

Note (1) Definition of Viewing Angle (θ_x, θ_y):

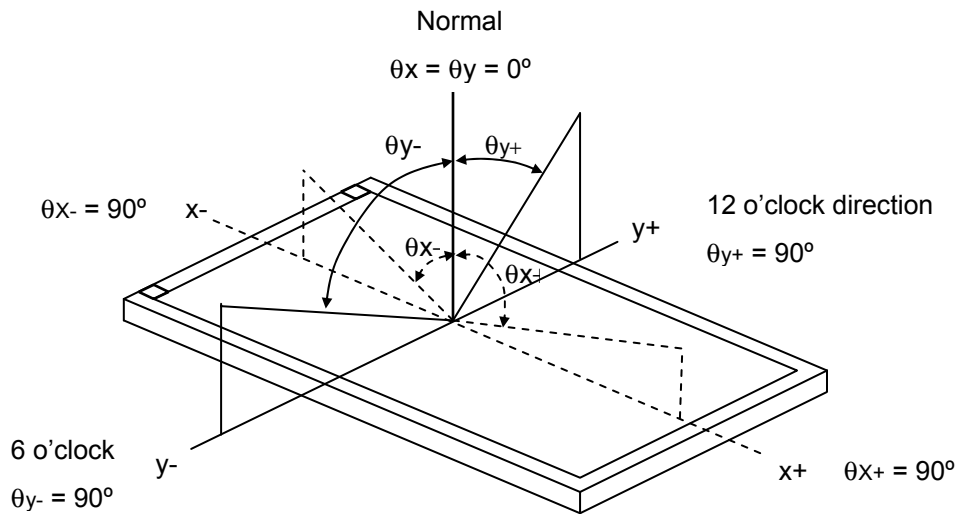

Note (2) Definition of Contrast Ratio (CR):

The contrast ratio can be calculated by the following expression.

$$\text{Contrast Ratio (CR)} = L_{255} / L_0$$

L255: Luminance of gray level 255

L 0: Luminance of gray level 0

CR = CR (5)

CR (X) is corresponding to the Contrast Ratio of the point X at Figure in Note (6).

Note (3) Definition of Response Time (T_R , T_F):

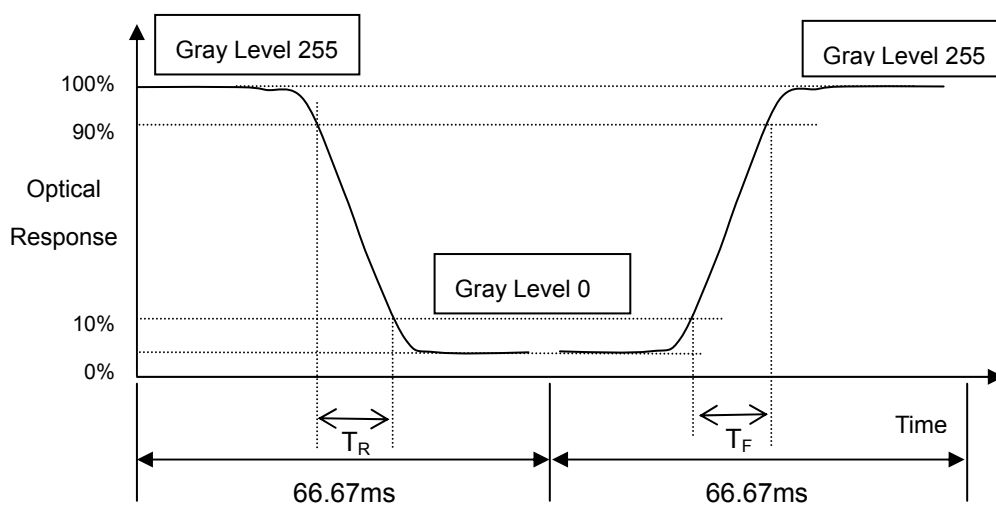

Note (4) Definition of Luminance of White (L_C):

Measure the luminance of gray level 255 at center point

$$L_c = L(5)$$

L (x) is corresponding to the luminance of the point X at Figure in Note (6).

Note (5) Measurement Setup:

The LCD module should be stabilized at given temperature for 40 minutes to avoid abrupt temperature change during measuring. In order to stabilize the luminance, the measurement should be executed after lighting Backlight for 40 minutes in a windless room.

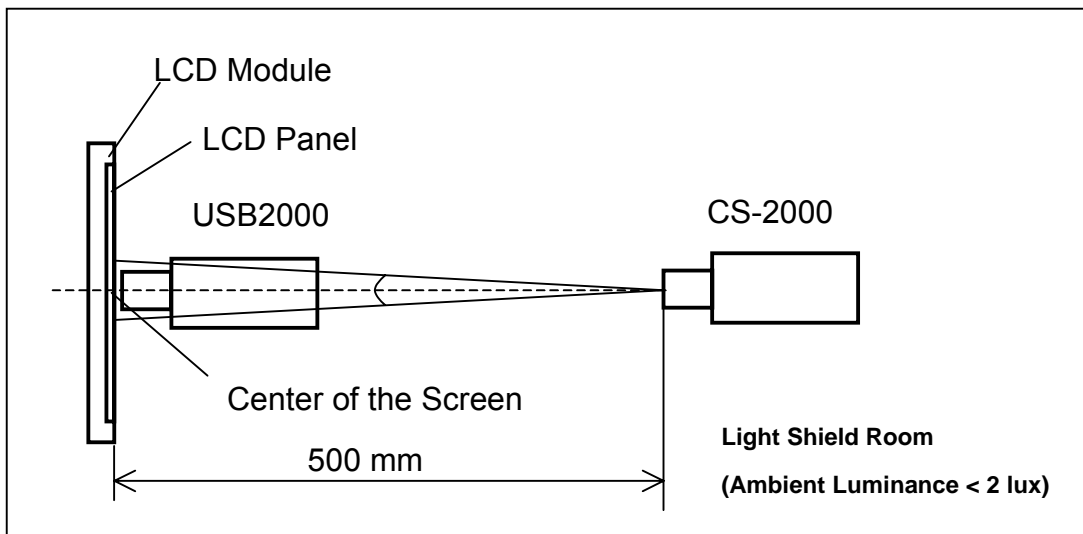

Note (6) Definition of White Variation (δW): Measure the luminance of gray level 255 at 9 points

$$\delta W = \text{Maximum [L (1) ~ L (9)]} / \text{Minimum [L (1) ~ L (9)]}$$

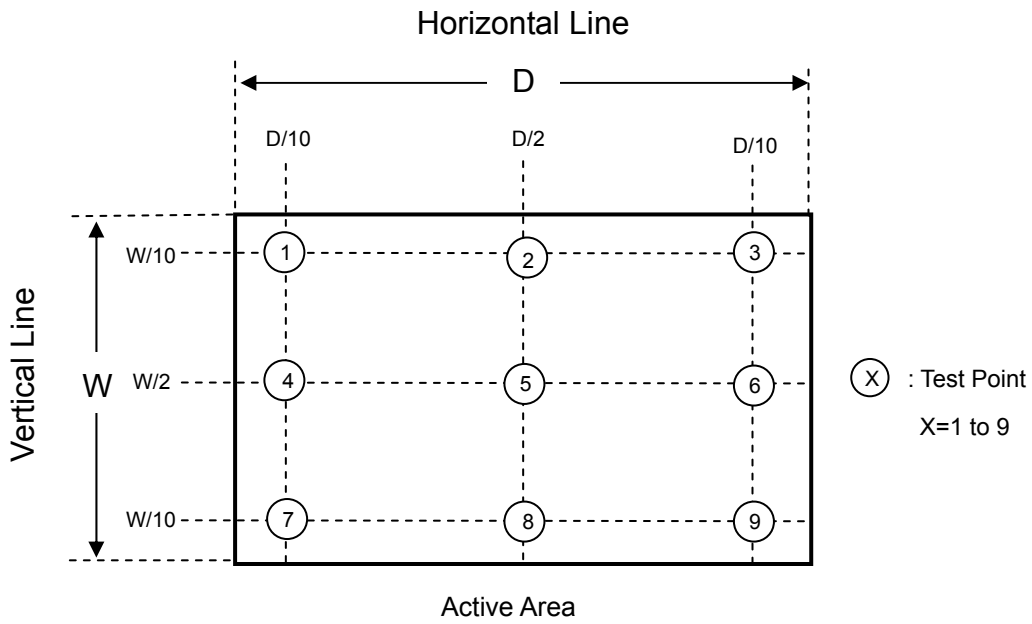

8. PACKAGING

8.1 PACKING SPECIFICATIONS

- (1) 11 LCD modules / 1 Box
- (2) Box dimensions: 620(L) X 348(W) X 430(H) mm
- (3) Weight: approximately: 30.1kg (11 modules per box)

8.2 PACKING METHOD

- (1) Carton Packing should have no failure in the following reliability test items.

Test Item	Test Conditions	Note
Vibration	ISTA STANDARD Random, Frequency Range: 1 – 200 Hz Top & Bottom: 30 minutes (+Z), 10 min (-Z), Right & Left: 10 minutes (X) Back & Forth 10 minutes (Y)	Non Operation
Dropping Test	1 Corner , 3 Edge, 6 Face, 31cm	Non Operation

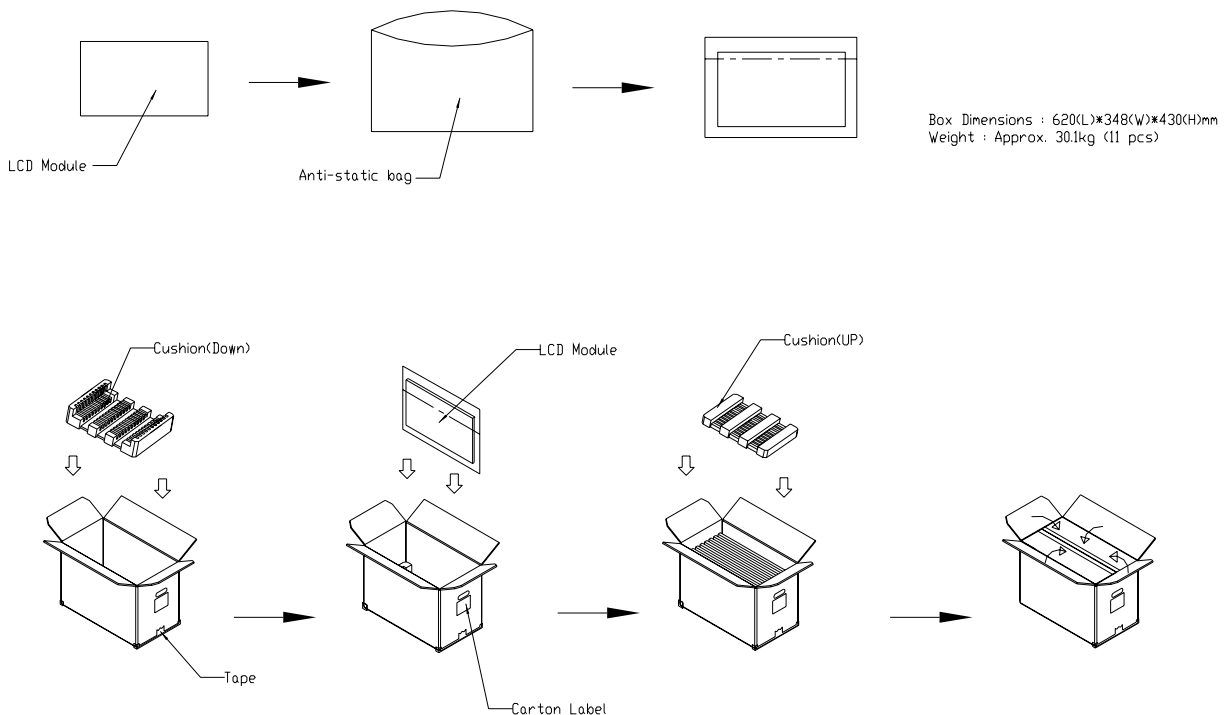
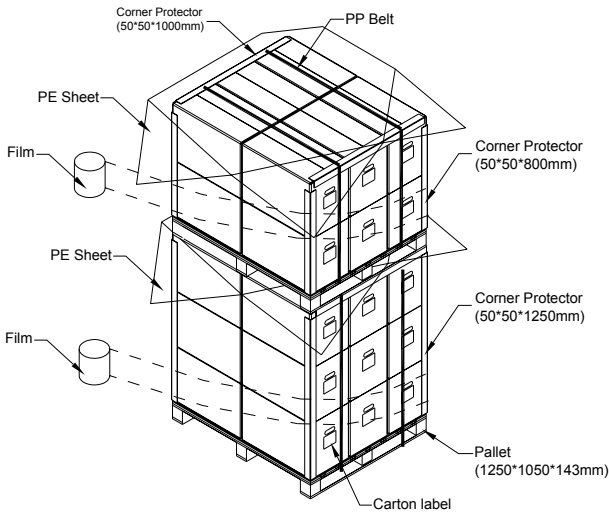

Figure. 8-1 Packing method

For ocean shipping

Sea / Land Transportation (40ft HQ Container)



Sea / Land Transportation (40ft Container)

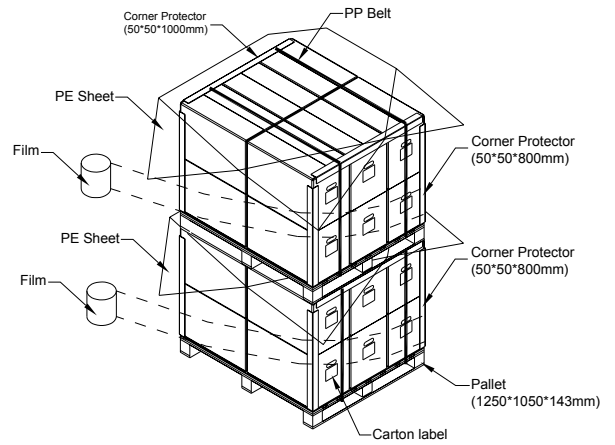

Figure. 8-2 Packing method

For air transport

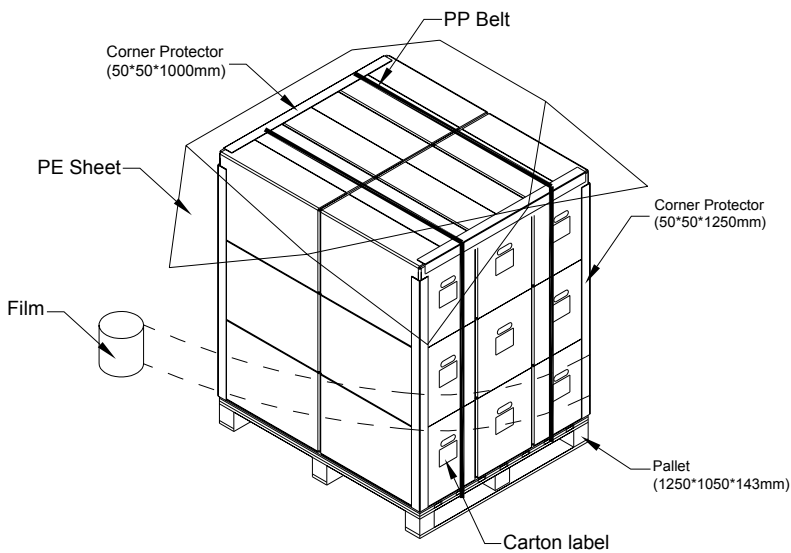

Figure. 8-3 Packing method

9. DEFINITION OF LABELS

9.1 CMO MODULE LABEL

The barcode nameplate is pasted on each module as illustration, and its definitions are as following explanation.



- (a) Model Name: M236H3-LA2
- (b) Revision: Rev. XX, for example: A0, A1... B1, B2... or C1, C2...etc.
- (c) CMO barcode definition:

Serial ID: XX-XX-X-XX-YMD-L-NNNN

Code	Meaning	Description
XX	CMO internal use	-
XX	Revision	Cover all the change
X	CMO internal use	-
XX	CMO internal use	-
YMD	Year, month, day	Year: 2001=1, 2002=2, 2003=3, 2004=4... Month: 1~12=1, 2, 3, ~, 9, A, B, C Day: 1~31=1, 2, 3, ~, 9, A, B, C, ~, W, X, Y, exclude I, O, and U.
L	Product line #	Line 1=1, Line 2=2, Line 3=3, ...
NNNN	Serial number	Manufacturing sequence of product

- (d) Customer's barcode definition:

Serial ID: CM-N63A2-X-X-X-XX-L-XX-L-YMD-NNNN

Code	Meaning	Description
CM	Supplier code	CMO=CM
N63A2	Model number	M236H3-LA2= N63A2
X	Revision code	Non ZBD: 1,2,~,8,9 / ZBD: A~Z
X	Source driver IC code	Century=1, CLL=2, Demos=3, Epson=4, Fujitsu=5, Himax=6, Hitachi=7, Hynix=8, LDI=9, Matsushita=A, NEC=B, Novatec=C, OKI=D, Philips=E, Renasas=F, Samsung=G, Sanyo=H, Sharp=I, TI=J, Topro=K, Toshiba=L, Windbond=M
X	Gate driver IC code	
XX	Cell location	Tainan Taiwan=TN, Ningbo China=CN
L	Cell line #	1,2,~,9,A,B,~,Y,Z
XX	Module location	Tainan, Taiwan=TN ; Ningbo China=NP
L	Module line #	1,2,~,9,A,B,~,Y,Z
YMD	Year, month, day	Year: 2001=1, 2002=2, 2003=3, 2004=4... Month: 1~12=1, 2, 3, ~, 9, A, B, C Day: 1~31=1, 2, 3, ~, 9, A, B, C, ~, T, U, V
NNNN	Serial number	By LCD supplier

- (e) FAB ID(UL Factory ID):

Region	Factory ID
TWCMO	GEMN
NBCMO	LEOO
NBCME	CANO
NHCMO	CAPG

10. Reliability Test

Environment test conditions are listed as following table.

Items	Required Condition	Note
Temperature Humidity Bias (THB)	Ta= 50 , 80%RH, 240hours	
High Temperature Operation (HTO)	Ta= 50 , 50%RH , 240hours	
Low Temperature Operation (LTO)	Ta= 0 , 240hours	
High Temperature Storage (HTS)	Ta= 60 , 240hours	
Low Temperature Storage (LTS)	Ta= -20 , 240hours	
Vibration Test (Non-operation)	Acceleration: 1.5 Grms Wave: Half-sine Frequency: 10 - 300 Hz Sweep: 30 Minutes each Axis (X, Y, Z)	
Shock Test (Non-operation)	Acceleration: 50 G Wave: Half-sine Active Time: 11 ms Direction : ± X, ± Y, ± Z.(one time for each Axis)	
Thermal Shock Test (TST)	-20 /30min , 60 / 30min , 100 cycles	
On/Off Test	25 , On/10sec , Off /10sec , 30,000 cycles	
ESD (Electro Static Discharge)	Contact Discharge: ± 8KV, 150pF(330Ω)	
	Air Discharge: ± 15KV, 150pF(330Ω)	
Altitude Test	Operation:10,000 ft / 24hours	
	Non-Operation:30,000 ft / 24hours	

11. PRECAUTIONS

11.1 ASSEMBLY AND HANDLING PRECAUTIONS

- (1) Do not apply rough force such as bending or twisting to the module during assembly.
- (2) To assemble or install module into user's system can be only in clean working areas. The dust and oil may cause electrical short or worsen the polarizer.
- (3) It's not permitted to have pressure or impulse on the module because the LCD panel and Backlight will be damaged.
- (4) Always follow the correct power sequence when LCD module is connecting and operating. This can prevent damage to the CMOS LSI chips during latch-up.
- (5) Do not pull the I/F connector in or out while the module is operating.
- (6) Do not disassemble the module.
- (7) Use a soft dry cloth without chemicals for cleaning, because the surface of polarizer is very soft and easily scratched.
- (8) It is dangerous that moisture come into or contacted the LCD module, because moisture may damage LCD module when it is operating.
- (9) High temperature or humidity may reduce the performance of module. Please store LCD module within the specified storage conditions.
- (10) When ambient temperature is lower than 10°C may reduce the display quality. For example, the response time will become slowly,

11.2 SAFETY PRECAUTIONS

- (1) If the liquid crystal material leaks from the panel, it should be kept away from the eyes or mouth. In case of contact with hands, skin or clothes, it has to be washed away thoroughly with soap.
- (2) After the module's end of life, it is not harmful in case of normal operation and storage.

11.3 SAFETY STANDARDS

The LCD module should be certified with safety regulations as follows:

- (1) UL60950-1 or updated standard.
- (2) IEC60950-1 or updated standard.

11.4. Storage

- (1) Do not leave the module in high temperature, and high humidity for a long time.
It is highly recommended to store the module with temperature from 0 to 35
And relative humidity of less than 70%
- (2) Do not store the TFT – LCD module in direct sunlight
- (3) The module should be stored in dark place. It is prohibited to apply sunlight or fluorescent light in storing

11.5. Operation condition guide

- (1) The LCD product should be operated under normal condition.

Normal condition is defined as below :

Temperature : 20 ± 15

Humidity: $65\pm 20\%$

Display pattern : continually changing pattern(Not stationary)

- (2) If the product will be used in extreme conditions such as high temperature , high humidity , high altitude , display pattern or operation time etc...It is strongly recommended to contact CMO for application engineering advice . Otherwise , Its reliability and function may not be guaranteed.

11.6 OTHER

When fixed patterns are displayed for a long time, remnant image is likely to occur.

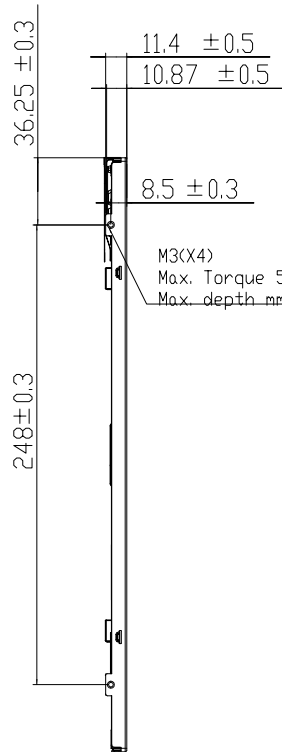

Data CDF Position
G1 Mechanical structure should not touch the positions of Data CDF

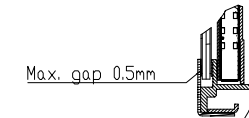
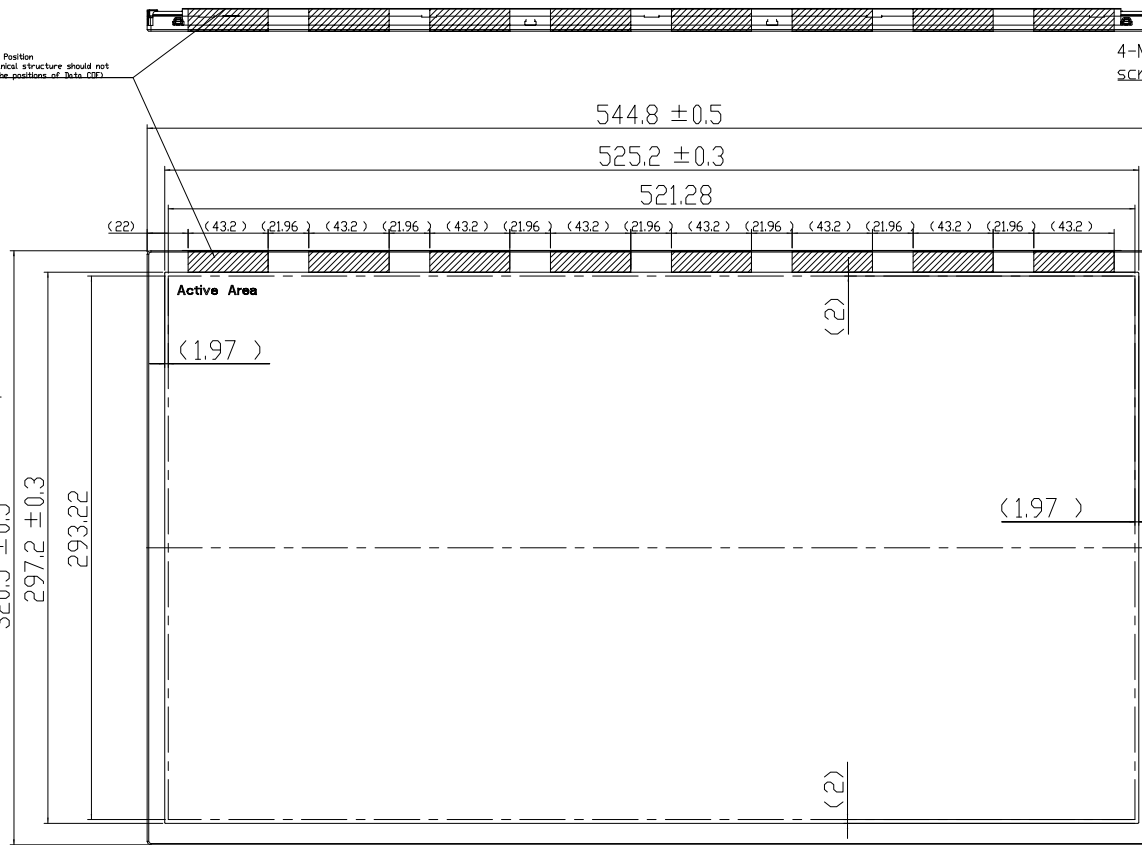

4-M3 User hole
screw length 4.5mm (max.)

SECTION USERHOLE_2D-USERHOLE_2D
SCALE 3:1

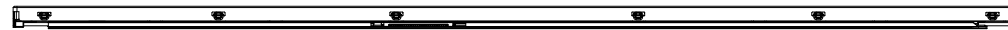
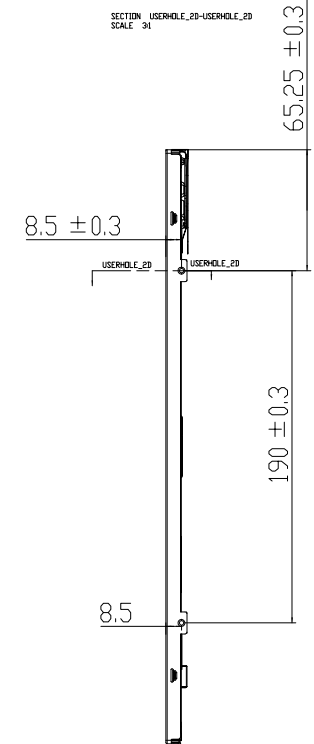

NOTES:
 1.UNSPECIFIED TOLERANCE : ±0.5mm.
 2.SIDE MOUNT HOLE TORQUE SPEC:5kgf-cm(Max.)
 3.SCREW LENGTH FLLW THE NOTES IN THE DRAWING
 4.Display area position tolerance: | A-BK=1mm & | C-DK=1mm.

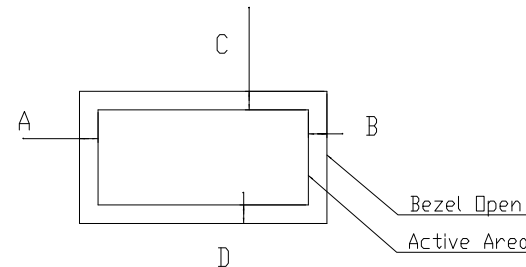

Mark	Description	Date	Changed_By	Approved_By	ECN No.	Remark
1						
2						
3						

TITLE ASSY_MIDDLE_PANEL-1A2				REV. NO.	
Approved	TBD	Drawing No.	ICKM450A	REV. 1	1/1
Checked	TBD	Part No.	TBD		
Designer	TBD	Release	TBD	Sheet 1 / 2	M
Designer	TBD	Scale	1:1	© 2015 CHIMEI OPTOELECTRONICS CORP. ALL RIGHTS RESERVED. COPYING FORBIDDEN.	

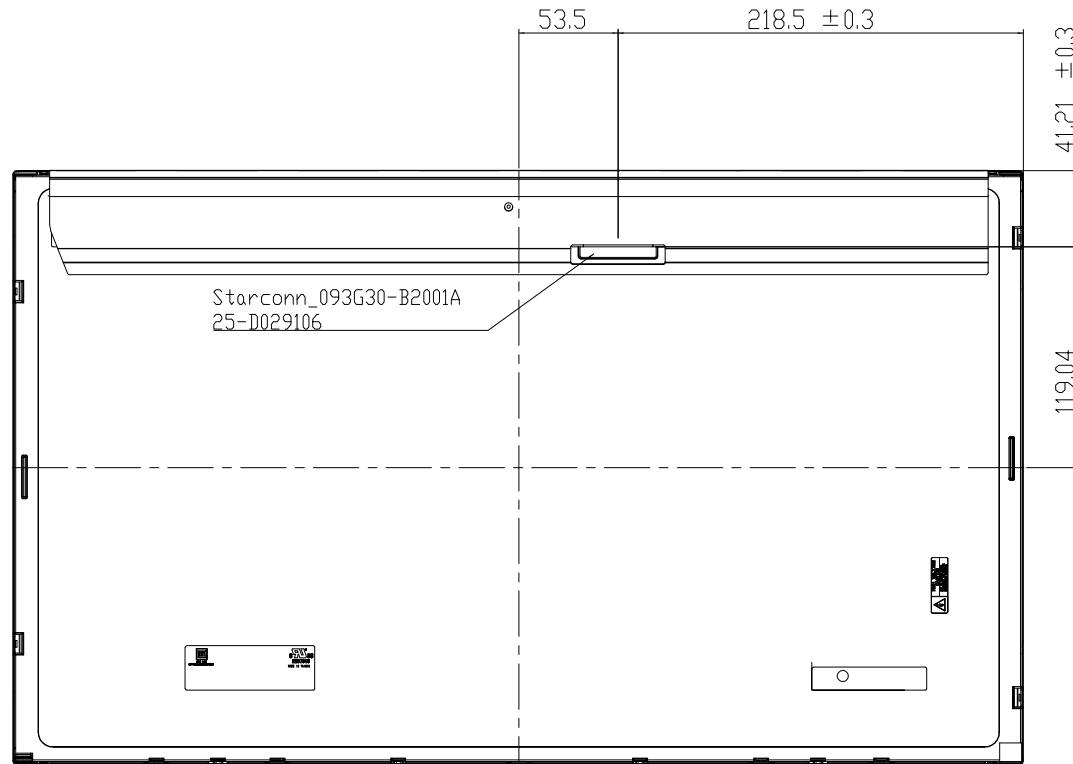

NOTES
 1 UNSPECIFIED TOLERANCE : ±0.5mm
 2 SINE WAVE MOUNT HOLE TORQUE SPEC(Spec-cmNo.3)
 3 SCREW LENGTH FOLLOW THE NOTES IN THE DRAWING

Mark	Description	Date	Changed_By	Approved_By	ECN No.	Remark
1						
2						
3						

TITLE: ASSY_MIDDLE_MOUNT_4AR		REV: 1	
Approved: TTD	Drawing No: MCKM450A	BY: MCK/LLH	
Checked: TTD	Part No: TTD		
Designer: TTTing_Tan	Release: TTD	Sheet: 1 / 3 of 1	
CHI MEI OPTOELECTRONICS CORP. ALL RIGHTS RESERVED. COPYING FORBIDDEN.			