



Product Specification

AU OPTRONICS CORPORATION

B170PW06 V2

(V) Preliminary Specifications

() Final Specifications

Module	17.0" WXGA+ Color TFT-LCD
Model Name	B170PW06 V2

Customer	Date
_____	_____
Checked & Approved by	
_____ Howard Lee _____	_____ 2006/1/26 _____
<p>Note: This Specification is subject to change without notice.</p>	

Approved by	Date
_____	_____
Prepared by	
_____ Maxine Lee _____	_____ 2006/1/26 _____
<p>NBBU Marketing Division / AU Optronics corporation</p>	



Contents

1. Handling Precautions	4
2. General Description	5
2.1 General Specification	5
2.2 Optical Characteristics	6
3. Functional Block Diagram	10
4. Absolute Maximum Ratings	11
4.1 Absolute Ratings of TFT LCD Module	11
4.2 Absolute Ratings of Backlight Unit	11
4.3 Absolute Ratings of Environment	11
5. Electrical characteristics	12
5.1 TFT LCD Module	12
5.2 Backlight Unit	14
6. Signal Characteristic	16
6.1 Pixel Format Image	16
6.2 The input data format	17
6.3 Signal Description	19
6.4 Interface Timing	20
6.5 Power ON/OFF Sequence	22
7. Connector Description	23
7.1 TFT LCD Module	23
7.2 Backlight Unit	23
7.3 Signal for Lamp connector	23
8. Vibration and Shock Test	24
8.1 Vibration Test	24
8.2 Shock Test Spec:	24
9. Reliability	25
10. Mechanical Characteristics	26
10.1 LCM Outline Dimension	26
10.2 Screw Hole Depth and Center Position	28
11. Shipping and Package	29
11.1 Shipping Label Format	29
11.2. Carton Package	29
12. Appendix: EDID description	30



Product Specification

AU OPTRONICS CORPORATION

B170PW06 V2

Record of Revision

Version and Date	Page	Old description	New Description	Remark
V0 2006/11/30		Initial Edition		



1. Handling Precautions

- 1) Since front polarizer is easily damaged, pay attention not to scratch it.
- 2) Be sure to turn off power supply when inserting or disconnecting from input connector.
- 3) Wipe off water drop immediately. Long contact with water may cause discoloration or spots.
- 4) When the panel surface is soiled, wipe it with absorbent cotton or other soft cloth.
- 5) Since the panel is made of glass, it may break or crack if dropped or bumped on hard surface.
- 6) Since CMOS LSI is used in this module, take care of static electricity and insure human earth when handling.
- 7) Do not open nor modify the Module Assembly.
- 8) Do not press the reflector sheet at the back of the module to any directions.
- 9) In case if a Module has to be put back into the packing container slot after once it was taken out from the container, do not press the center of the CCFL Reflector edge. Instead, press at the far ends of the CFL Reflector edge softly. Otherwise the TFT Module may be damaged.
- 10) At the insertion or removal of the Signal Interface Connector, be sure not to rotate nor tilt the Interface Connector of the TFT Module.
- 11) After installation of the TFT Module into an enclosure (Notebook PC Bezel, for example), do not twist nor bend the TFT Module even momentary. At designing the enclosure, it should be taken into consideration that no bending/twisting forces are applied to the TFT Module from outside. Otherwise the TFT Module may be damaged.
- 12) Cold cathode fluorescent lamp in LCD contains a small amount of mercury. Please follow local ordinances or regulations for disposal.
- 13) Small amount of materials having no flammability grade is used in the LCD module. The LCD module should be supplied by power complied with requirements of Limited Power Source (IEC60950 or UL1950), or be applied exemption.
- 14) The LCD module is designed so that the CCFL in it is supplied by Limited Current Circuit (IEC60950 or UL1950). Do not connect the CCFL in Hazardous Voltage Circuit.



Product Specification

AU OPTRONICS CORPORATION

B170PW06 V2

2. General Description

B170PW06 V2 is a Color Active Matrix Liquid Crystal Display composed of a TFT LCD panel, a driver circuit, and backlight system. The screen format is intended to support the WXGA+ (1440(H) x 900(V)) screen and 262k colors (RGB 6-bits data driver). All input signals are LVDS interface compatible. Inverter of backlight is not included.

B170PW06 V2 is designed for a display unit of notebook style personal computer and industrial machine.

2.1 General Specification

The following items are characteristics summary on the table at 25 °C condition:

Items	Unit	Specifications
Screen Diagonal	[mm]	391 (17.0W")
Active Area	[mm]	367.20(H) X 229.50(V)
Pixels H x V		1440x3(RGB)x900
Pixel Pitch	[mm]	0.255X0.255
Pixel Arrangement		R.G.B. Vertical Stripe
Display Mode		Normally White
White Luminance (I _{CCFL} =6.5mA) Note: I _{CCFL} is lamp current	[cd/m ²]	220 typ. (5 points average) 200 min. (5 points average) (Note1)
Luminance Uniformity		1.2 max. (5 points)
Contrast Ratio		500 typ
Optical Rise Time/Fall Time	[msec]	8ms typ. (14ms max)
Nominal Input Voltage VDD	[Volt]	+3.3 typ. (+3.0 min, +3.6 max)
Power Consumption	[Watt]	7 typ (without inverter)
Weight	[Grams]	660 typ. (700 max)
Physical Size	[mm]	TYP: 382.2(W)x244.5(H)x6.4 (D) MAX:382.7(W)x245.0(H)x7.0 (D)
Electrical Interface		2 channel LVDS
Surface Treatment		Glare, Hard Coating (3H)
Support Color		Native 262K colors (RGB 6-bit Data driver)
Temperature Range Operating Storage (Non-Operating)	[°C] [°C]	0 to +50 -20 to +60
RoHS Compliance		RoHS Compliance



Product Specification

AU OPTRONICS CORPORATION

B170PW06 V2

2.2 Optical Characteristics

The optical characteristics are measured under stable conditions at 25°C (Room Temperature):

Item	Unit	Conditions	Min.	Typ.	Max.	Note
White Luminance I _{CCFL} =6.5mA	[cd/m ²]	5 points average	200	220	-	1, 4, 8
Viewing Angle	[degree]	Horizontal (Right)	40	45	-	7
	[degree]	CR = 10 (Left)	40	45	-	
	[degree]	Vertical (Upper)	15	20	-	
	[degree]	CR = 10 (Lower)	30	35	-	
Luminance Uniformity		5 Points			1.2	1,3
Luminance Uniformity		13 Points			1.5	2,3
CR: Contrast Ratio			400	500	-	4
Cross talk	%				4	5
Response Time	[msec]	Rising	-	2	5	6
	[msec]	Falling	-	6	9	
	[msec]	Rising + Falling		8	14	
Color / Chromaticity Coordinates (CIE 1931)		Red x	0.560	0.590	0.620	2,7
		Red y	0.315	0.345	0.375	
		Green x	0.285	0.315	0.345	
		Green y	0.525	0.555	0.585	
		Blue x	0.125	0.155	0.185	
		Blue y	0.125	0.155	0.185	
		White x	0.283	0.313	0.343	
		White y	0.299	0.329	0.359	

Note 1: 5 points position (Display area : 367.20(H) X 229.50(V))mm

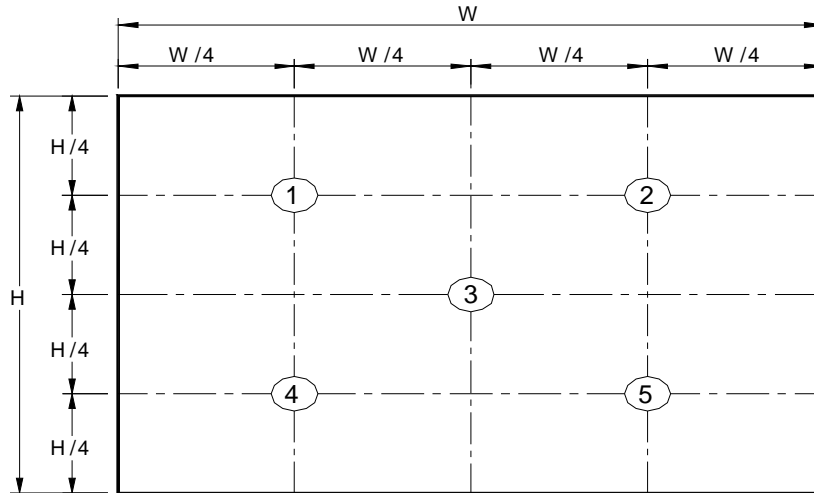

Note 2: 13 points position

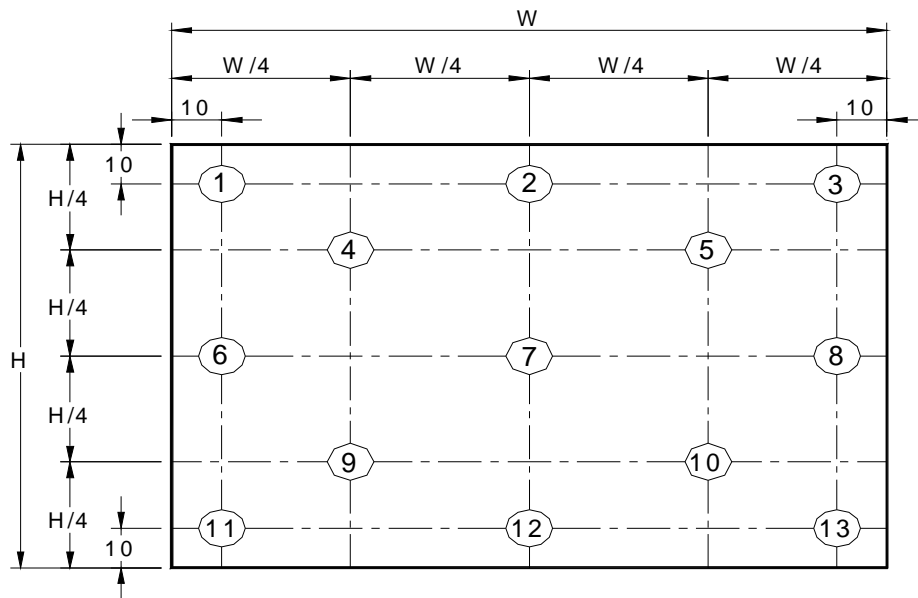

Note 3: The luminance uniformity of 5 and 13 points is defined by dividing the maximum luminance values by the minimum test point luminance

$$\delta_{W5} = \frac{\text{Maximum Brightness of five points}}{\text{Minimum Brightness of five points}}$$

$$\delta_{W13} = \frac{\text{Maximum Brightness of thirteen points}}{\text{Minimum Brightness of thirteen points}}$$

Note 4: Measurement method

The LCD module should be stabilized at given temperature for 30 minutes to avoid abrupt temperature change during measuring. In order to stabilize the luminance, the measurement should be executed after lighting Backlight for 30 minutes in a stable, windless and dark room.

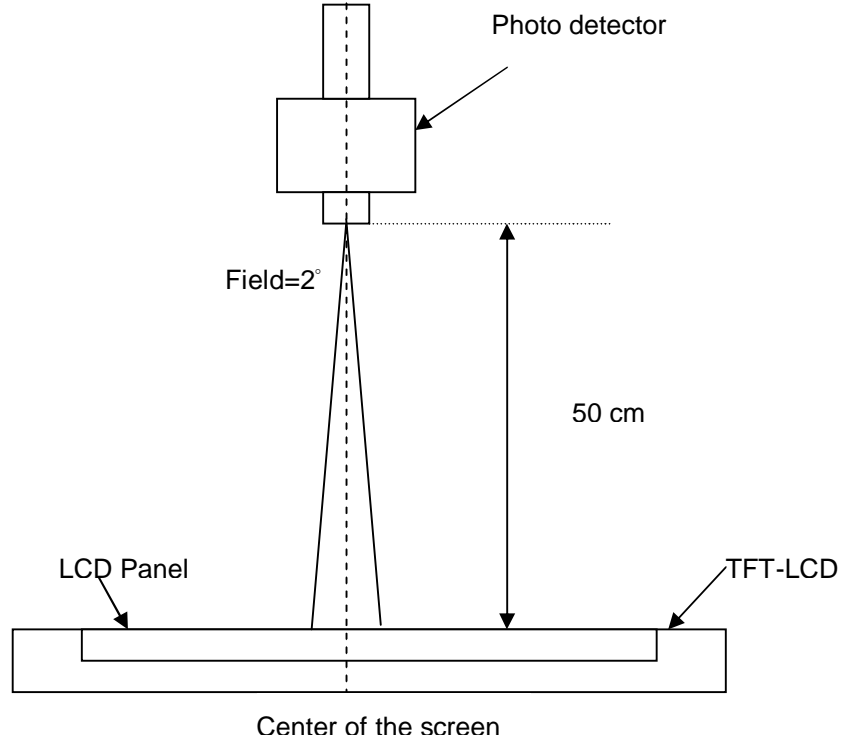

Note 5 : Definition of Cross Talk (CT)

$$CT = | Y_B - Y_A | / Y_A \times 100 (\%)$$

Where

Y_A = Luminance of measured location without gray level 0 pattern (cd/m^2)

Y_B = Luminance of measured location with gray level 0 pattern (cd/m^2)

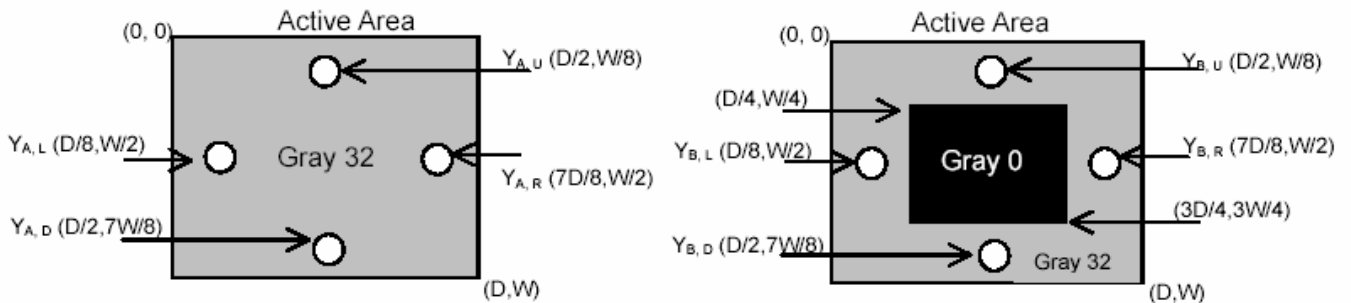

Note 6: Definition of response time:

The output signals of BM-7 or equivalent are measured when the input signals are changed from "Black" to "White" (falling time) and from "White" to "Black" (rising time), respectively. The response time interval between the 10% and 90% of amplitudes. Refer to figure as below.

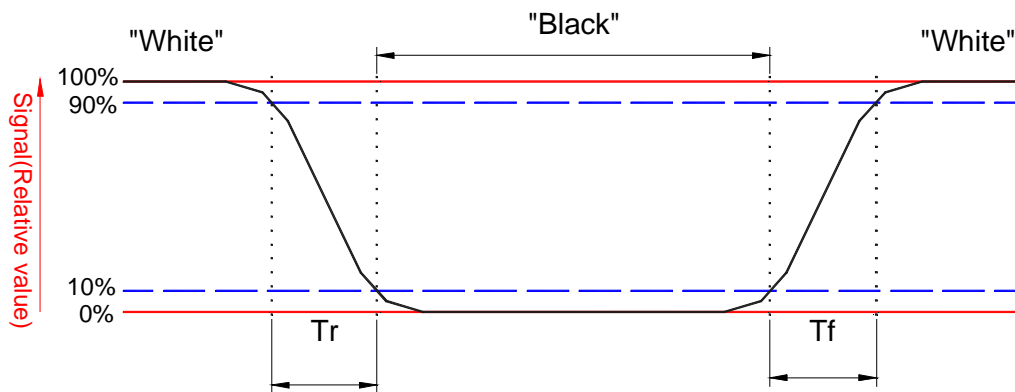

Note 7. Definition of viewing angle

Viewing angle is the measurement of contrast ratio ≥ 10 , at the screen center, over a 180° horizontal and 180° vertical range (off-normal viewing angles). The 180° viewing angle range is broken down as follows; 90° (θ) horizontal left and right and 90° (Φ) vertical, high (up) and low (down). The measurement direction is typically perpendicular to the display surface with the screen rotated about its center to develop the desired measurement viewing angle.

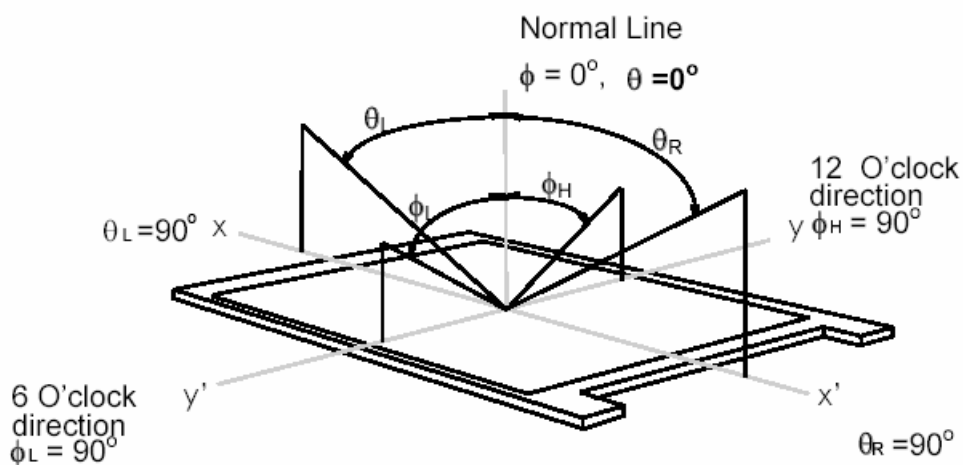

Note 8. Brightness measured with Foxconn inverter T73I019.01, under 6.5mA lamp current input.

3. Functional Block Diagram

The following diagram shows the functional block of the 17.0 inches wide Color TFT/LCD Module:

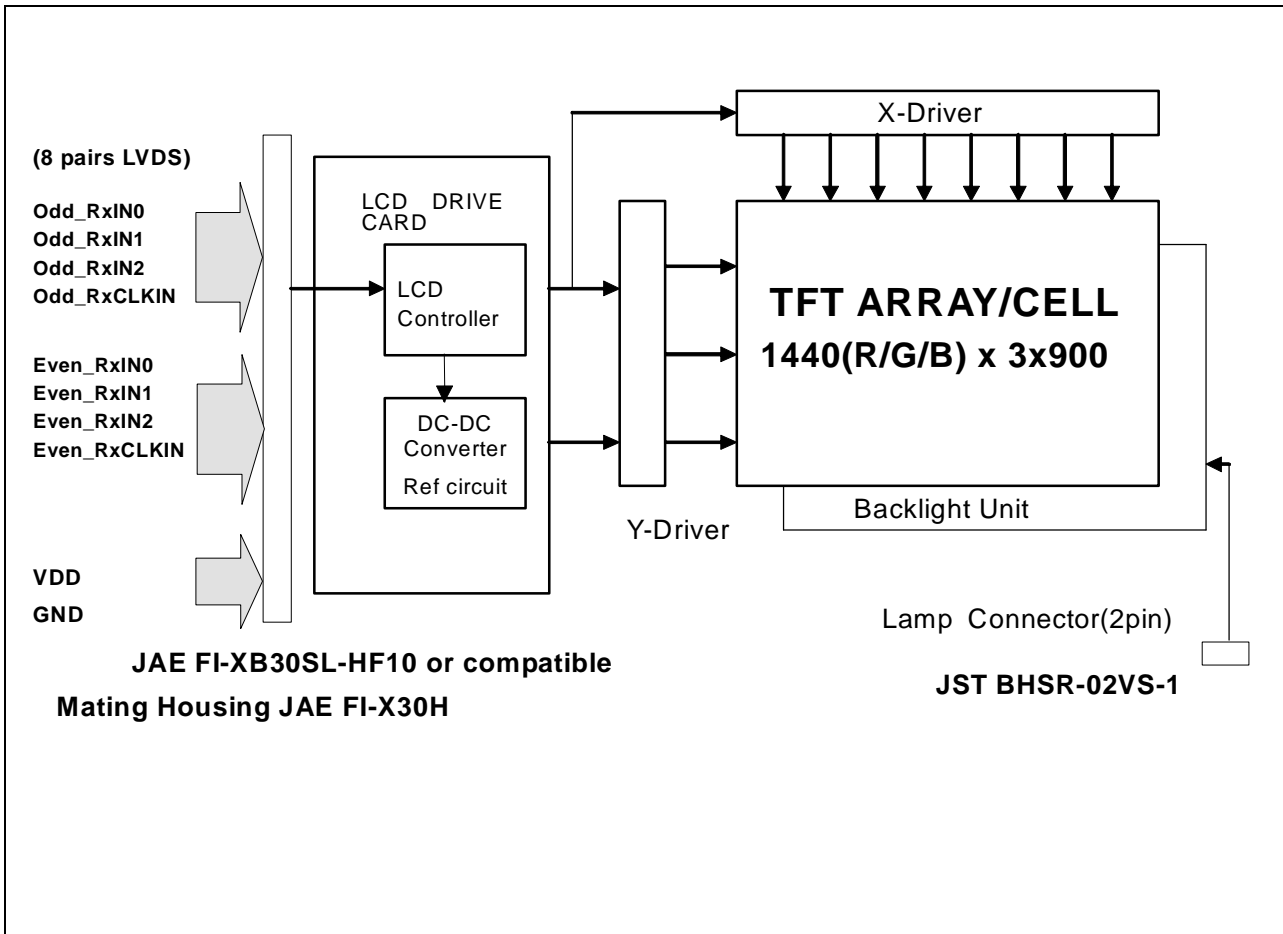

4. Absolute Maximum Ratings

Absolute maximum rating of the module is as following:

4.1 Absolute Ratings of TFT LCD Module

Item	Symbol	Min	Max	Unit	Conditions
Logic/LCD Drive	Vin	-0.3	+4.0	[Volt]	Note 1,2

4.2 Absolute Ratings of Backlight Unit

Item	Symbol	Min	Max	Unit	Conditions
CCFL Current	ICCFL	-	7	[mA] rms	Note 1,2

4.3 Absolute Ratings of Environment

Item	Symbol	Min	Max	Unit	Conditions
Operating Temperature	TOP	0	+50	[°C]	Note 3
Operation Humidity	HOP	5	95	[%RH]	Note 3
Storage Temperature	TST	-20	+60	[°C]	Note 3
Storage Humidity	HST	5	95	[%RH]	Note 3

Note 1: Within Ta (25°C)

Note 2: Permanent damage to the device may occur if exceed maximum values

Note 3: For quality performance, please refer to AUO IIS(Incoming Inspection Standard).

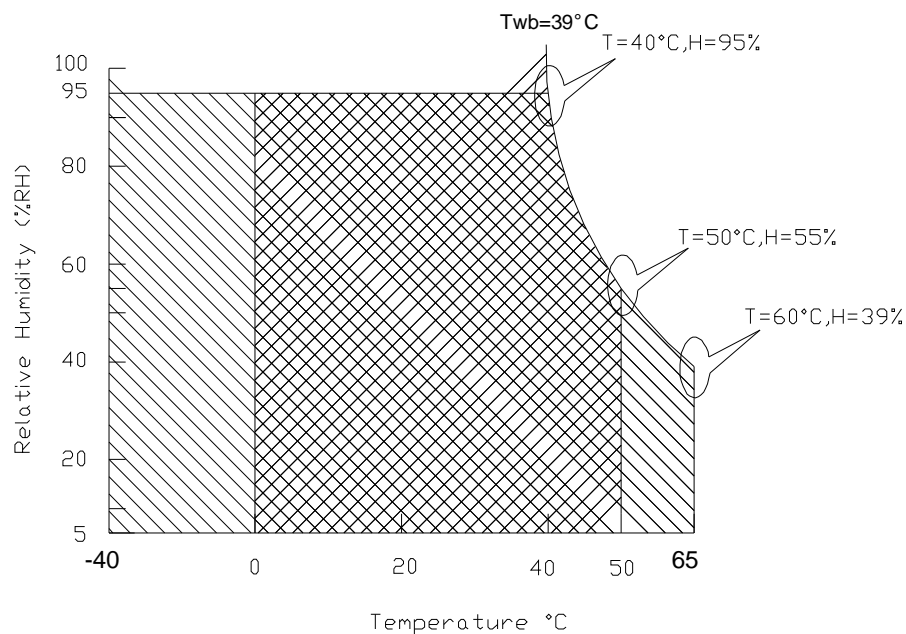

Operating Range



Storage Range



5. Electrical characteristics

5.1 TFT LCD Module

5.1.1 Power Specification

Input power specifications are as follows;

Symble	Parameter	Min	Typ	Max	Units	Note
VDD	Logic/LCD Drive Voltage	3.0	3.3	3.6	[Volt]	
PDD	VDD Power			2.1	[Watt]	Note 1
IDD	IDD Current		580	680	[mA]	Note 1 , VDD=3.3 V
IRush	Inrush Current			2000	[mA]	Note 2
VDDrp	Allowable Logic/LCD Drive Ripple Voltage			100	[mV] p-p	

Note 1 : Maximum Measurement Condition : Black Pattern

Note 2 : Measure Condition

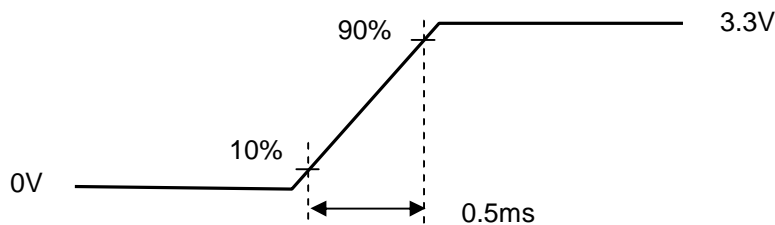
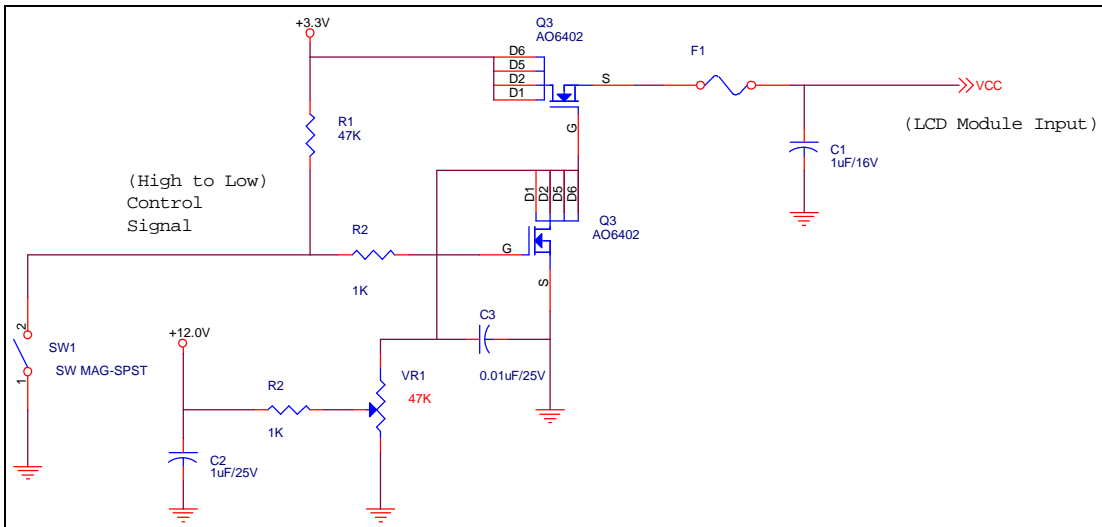

Vin rising time

5.1.2 Signal Electrical Characteristics

Input signals shall be low or High-impedance state when VDD is off.

Signal electrical characteristics are as follows;

Parameter	Condition	Min	Max	Unit
Vth	Differential Input High Threshold ($V_{cm}=+1.2V$)		100	[mV]
Vtl	Differential Input Low Threshold ($V_{cm}=+1.2V$)	-100		[mV]
Vcm	Differential Input Common Mode Voltage	1.1	1.45	[V]

Note: LVDS Differential Voltage

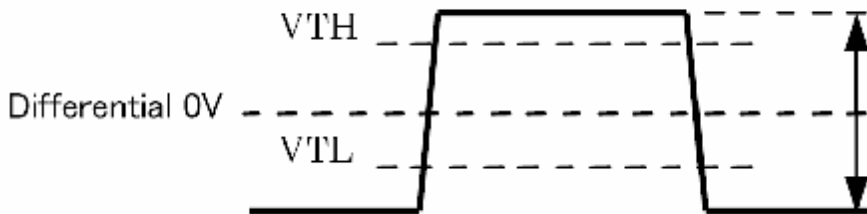

5.2 Backlight Unit

Parameter guideline for CCFL Inverter

Parameter	Min	Typ	Max	Units	Condition
White Luminance	2250	2450	—	[cd/m ²]	(Ta=25°C) Note 1
CCFL current(ICCFL)	3.0	6.5	7.0	[mA] rms	(Ta=25°C) Note 2
CCFL Frequency (FCCFL)	40	60	80	[KHz]	(Ta=25°C) Note 3,4
CCFL Ignition Voltage (Vs)	—	—	1700	[Volt] rms	(Ta= 0°C) Note 5
CCFL Ignition Voltage(Vs)	—	—	1310	[Volt] rms	(Ta= 25°C) Note 5
CCFL Voltage (Reference)	666	740	814	[Volt] rms	(Ta=25°C) Note 6
CCFL Power consumption	2.22	4.8	5.2	[Watt]	(Ta=25°C) Note 6
CCFL Set up Time	1	—	—	[Sec]	

Note 1: Typ are AUO recommended Design Points.

*1 All of characteristics listed are measured under the condition using the AUO Test inverter.

*2 In case of using an inverter other than listed, it is recommended to check the inverter carefully.

Sometimes, interfering noise stripes appear on the screen, and substandard luminance or flicker at low power may happen.

*3 In designing an inverter, it is suggested to check safety circuit very carefully. Impedance of CCFL, for instance, becomes more than 1 [M ohm] when CFL is damaged.

*4 Generally, CCFL has some amount of delay time after applying kick-off voltage. It is recommended to keep on applying kick-off voltage for 1 [Sec] until discharge.

*5 CCFL discharge frequency must be carefully chosen so as not to produce interfering noise stripes on the screen.

*6 Reducing CCFL current increases CCFL discharge voltage and generally increases CCFL discharge frequency. So all the parameters of an inverter should be carefully designed so as not to produce too much leakage current from high-voltage output of the inverter.

Note 2: It should be employed the inverter which has “Duty Dimming”, if ICCFL is less than 4mA.

Note 3: CCFL discharge frequency should be carefully determined to avoid interference between inverter and TFT LCD.

Note 4: The frequency range will not affect to lamp life and reliability characteristics.

B170PW06 V2

Note 5: CCFL inverter should be able to give out a power that has a generating capacity of over 1,430 voltage. Lamp units need 1,400 voltage minimum for ignition.

Note 6: Calculator value for reference ($I_{CCFL} \times V_{CCFL} = P_{CCFL}$)

Note 7: Requirements for a system inverter design, which is intended to have a better display performance, a better power efficiency and a more reliable lamp, are following.

It shall help increase the lamp lifetime and reduce leakage current.

- The asymmetry rate of the inverter waveform should be less than 10%.
- The distortion rate of the waveform should be within $\sqrt{2} \pm 10\%$.

* Inverter output waveform had better be more similar to ideal sine wave.

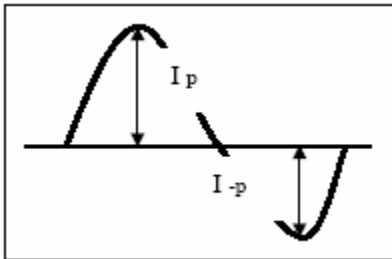

* Asymmetry rate:

$$\frac{|I_p - I_{-p}|}{I_{rms}} * 100\%$$

* Distortion rate

$$I_p \text{ (or } I_{-p}) / I_{rms}$$

6.2 The input data format

ODD pair(1st pixel input)

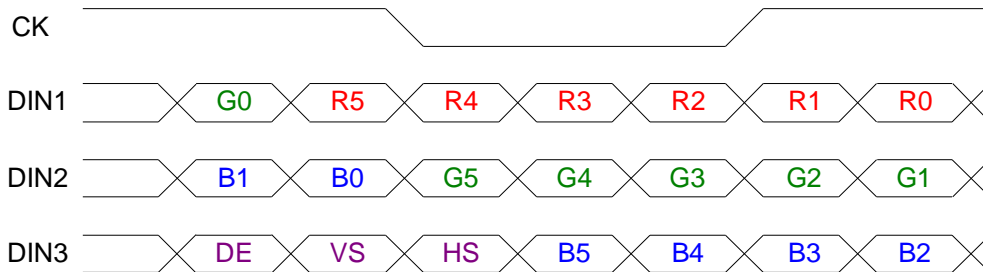

Even pair(2nd pixel input)

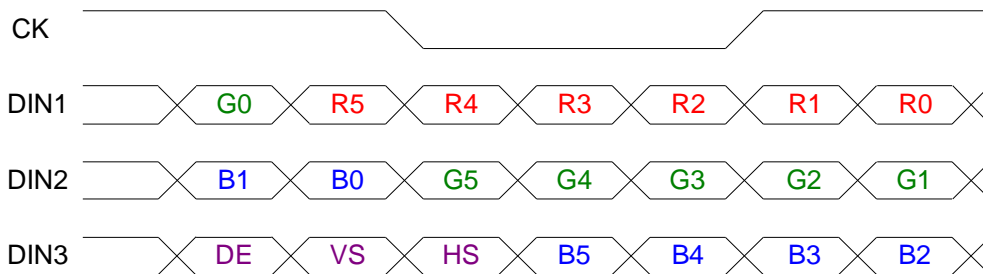

Signal Name	Description	
R5 R4 R3 R2 R1 R0	Red Data 5 (MSB) Red Data 4 Red Data 3 Red Data 2 Red Data 1 Red Data 0 (LSB) Red-pixel Data	Red-pixel Data Each red pixel's brightness data consists of these 6 bits pixel data.
G5 G4 G3 G2 G1 G0	Green Data 5 (MSB) Green Data 4 Green Data 3 Green Data 2 Green Data 1 Green Data 0 (LSB) Green-pixel Data	Green-pixel Data Each green pixel's brightness data consists of these 6 bits pixel data.
B5 B4 B3 B2 B1 B0	Blue Data 5 (MSB) Blue Data 4 Blue Data 3 Blue Data 2 Blue Data 1 Blue Data 0 (LSB) Blue-pixel Data	Blue-pixel Data Each blue pixel's brightness data consists of these 6 bits pixel data.
RxCLKIN	Data Clock	The typical frequency is 48.2 MHz. The signal is used to strobe the pixel data and DSPTMG signals. All pixel data shall be valid at the falling edge when the DSPTMG signal is high.



Product Specification

AU OPTRONICS CORPORATION

B170PW06 V2

DE	Display Timing	This signal is strobed at the falling edge of -DTCLK. When the signal is high, the pixel data shall be valid to be displayed.
VS	Vertical Sync	The signal is synchronized to -DTCLK .
HS	Horizontal Sync	The signal is synchronized to -DTCLK .

Note: Output signals from any system shall be low or Hi-Z state when VDD is off.



Product Specification

AU OPTRONICS CORPORATION

B170PW06 V2

6.3 Signal Description

LVDS is a differential signal technology for LCD interface and high speed data transfer device.

Pin no	Symbol	Function	Etc.
1	GND	Ground	
2	VDD	Power supply ,3.3 V (typical)	
3	VDD	Power supply ,3.3 V (typical)	
4	V _{EDID}	DDC 3.3V power	
5	NC	No Connection (Reserved for AUO) test	
6	CLK _{EDID}	DDC Clock	
7	Data _{EDID}	DDC data	
8	Odd_RxIN0-	-LVDS differential data input	
9	Odd_RxIN0+	+LVDS differential data input	
10	GND	Ground	
11	Odd_RxIN1-	-LVDS differential data input	
12	Odd_RxIN1+	+LVDS differential data input	
13	GND	Ground	
14	Odd_RxIN2-	-LVDS differential data input	
15	Odd_RxIN2+	+LVDS differential data input	
16	GND	Ground	
17	Odd_RxCLKIN-	-LVDS differential clock input	
18	Odd_RxCLKIN+	+LVDS differential clock input	
19	GND	Ground	
20	Even_RxIN0-	-LVDS differential data input	
21	Even_RxIN0+	+LVDS differential data input	
22	GND	Ground	
23	Even_RxIN1-	-LVDS differential data input	
24	Even_RxIN1+	+LVDS differential data input	
25	GND	Ground	
26	Even_RxIN2-	-LVDS differential data input	
27	Even_RxIN2+	+LVDS differential data input	
28	GND	Ground	
29	Even_RxCLKIN-	-LVDS differential clock input	
30	Even_RxCLKIN+	+LVDS differential clock input	

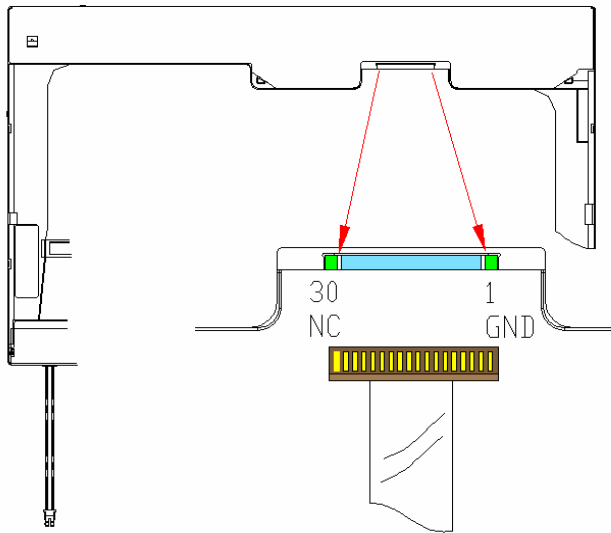

Note1: Start from right side

Note2: Please follow VESA standard.

Note3: Input signals shall be low or High-impedance when VDD is off.

Internal circuit of LVDS inputs are as following.

The module uses a 100ohm resistor between positive and negative data lines of each receiver input

6.4 Interface Timing

6.4.1 Timing Characteristics

Basically, interface timings should match the 1440x900 manufacturing guide line timing.

Signal	Item	Symbol	Min	Typ	Max	Unit
Vertical Section	Period	Tv	904	912	2048	Th
	Active	Tdisp(v)	900	900	900	Th
	Blanking	Tblk(v)	4	12	-	Th
Horizontal Section	Period	Th	760	880	1024	Tclk
	Active	Tdisp(h)	720	720	720	Tclk
	Blanking	Tblk(h)	40	160	-	Tclk
Clock	Period	Tclk	16.61	20.75	-	Ns
	Frequency@60Hz	Freq	-	48.2	60.2	MHz

Note : DE mode only

6.4.2 Timing diagram

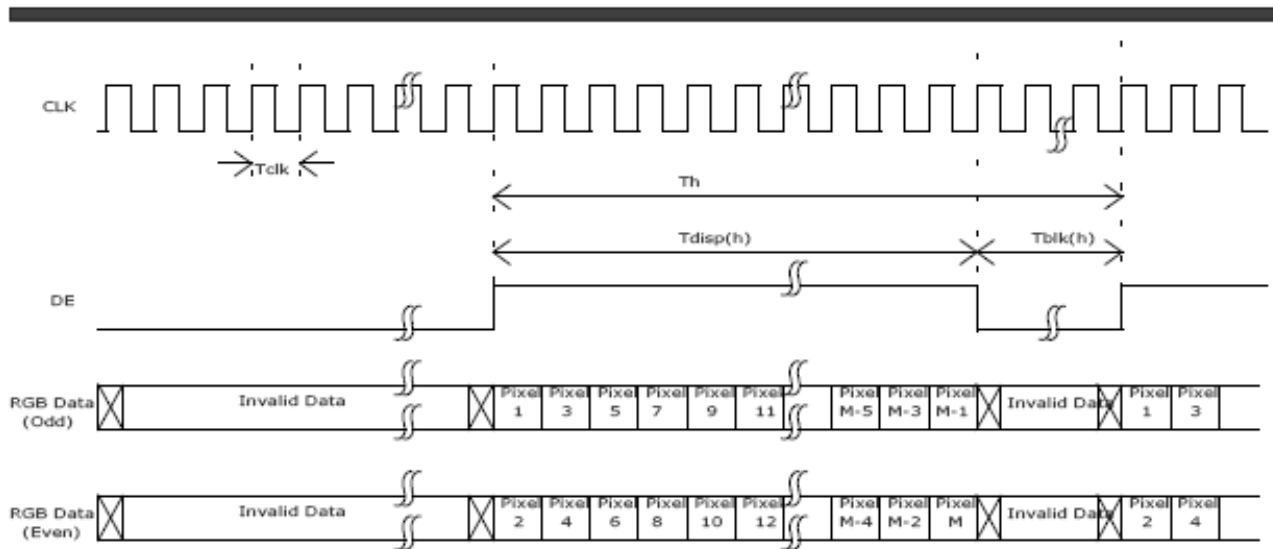
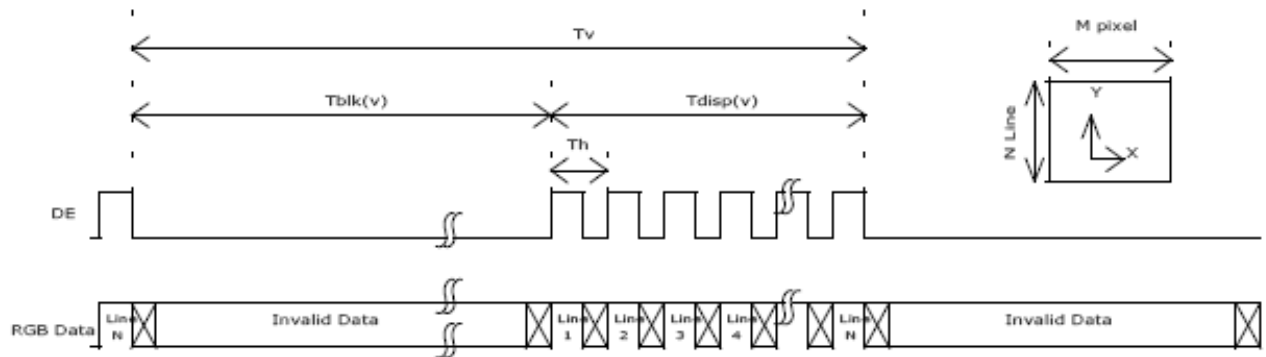

6.5 Power ON/OFF Sequence

VDD power and lamp on/off sequence is as follows. Interface signals are also shown in the chart. Signals from any system shall be Hi-Z state or low level when VDD is off.

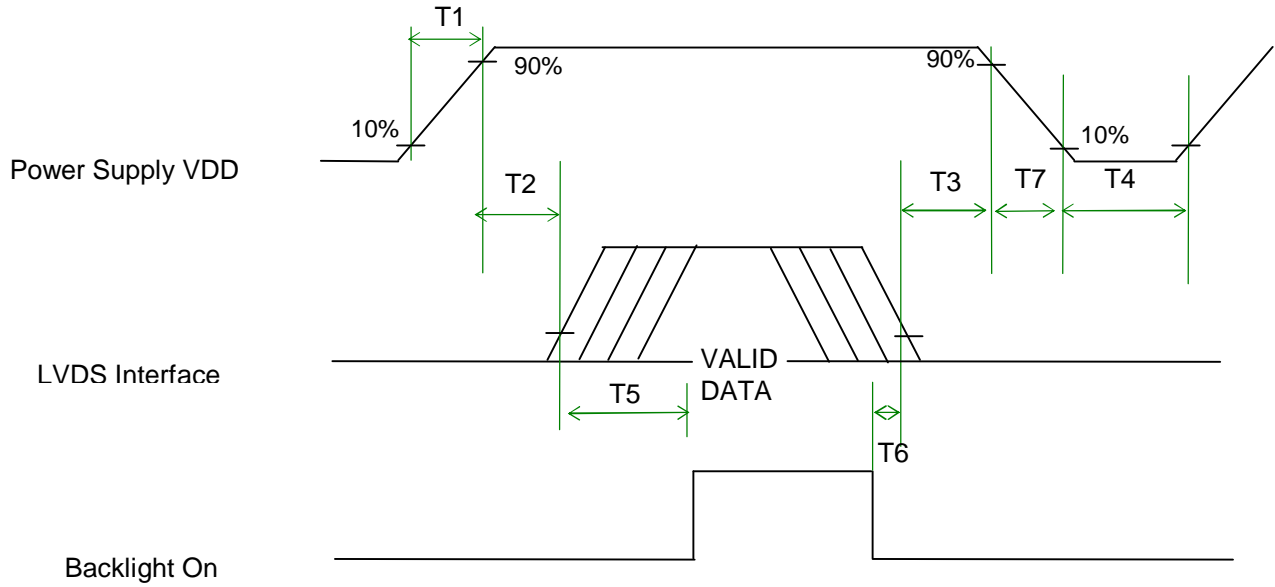

Power Sequence Timing

Parameter	Value			Units
	Min.	Typ.	Max.	
T1	0.5	-	10	(ms)
T2	0	-	50	(ms)
T3	0	-	50	(ms)
T4	500	-	-	(ms)
T5	200	-	-	(ms)
T6	200	-	-	(ms)
T7	0	-	10	(ms)



Product Specification

AU OPTRONICS CORPORATION

B170PW06 V2

7. Connector Description

Physical interface is described as for the connector on module.

These connectors are capable of accommodating the following signals and will be following components.

7.1 TFT LCD Module

Connector Name / Designation	For Signal Connector
Manufacturer	JAE or compatible
Type / Part Number	FI-XB30SL-HF10 or compatible
Mating Housing/Part Number	FI-X30H
Mating Contact/Part Number	FI-XC3-1-15000

7.2 Backlight Unit

Physical interface is described as for the connector on module.

These connectors are capable of accommodating the following signals and will be following components.

Connector Name / Designation	For Lamp Connector
Manufacturer	JST
Type / Part Number	BHSR-02VS-1
Mating Type / Part Number	SM02B-BHSS-1-TB

7.3 Signal for Lamp connector

Pin #	Cable color	Signal Name
1	Red	Lamp High Voltage
2	White	Lamp Low Voltage



8. Vibration and Shock Test

8.1 Vibration Test

Test Spec:

- I Test method: Non-Operation
- I Acceleration: 1.5G
- I Frequency: 10 - 500Hz Random
- I Sweep: 30 Minutes each Axis (X, Y, Z)

8.2 Shock Test Spec:

Test Spec:

- I Test method: Non-Operation
- I Acceleration: 180 G , Half sine wave
- I Active time: 2 ms
- I Pulse: X,Y,Z .one time for each side



Product Specification

AU OPTRONICS CORPORATION

B170PW06 V2

9. Reliability

Items	Required Conditions
Operating Life – High Temp.	Temp.= +50°C, Dynamic. 250 Hours, Humidity 20%
Operating Life – Low Temp.	Temp.= 0°C, Dynamic, 250 Hours, Humidity 20%
High Temp. Storage Life – Non-Operating	Temp.= +60°C, Non-Operating, 250 Hours, Humidity 20%
Low Temp. Storage Life – Non-Operating	Temp.= -20°C, Non-Operating, 250 Hours
High Temp & High Humidity Operating Life	Temp.=+40°C, Dynamic Humidity 95%(Non-Condensing), 250 Hours
Shock – Non-Operating	180g, 2.0 ms, Half Sine Wave
Vibration – Non-Operating	Random vibration, 1.5 G zero-to-peak, 10 to 500 Hz, 30 minutes in each of three mutually perpendicular axes
Temp. Cycle – Non-Operating	-20°C to +60°C, Ramp $\leq 20^\circ\text{C}/\text{min}$, Duration at Temp. = 30min, Test Cycles = 50
ESD	Contact : $\pm 8\text{KV}$ / operation Air : $\pm 15\text{KV}$ / operation
Room temperature Test	25°C, 2000hours, Operating with loop pattern

Note1: According to EN61000-4-2 , ESD class B: Some performance degradation allowed. No data lost

. Self-recoverable. No hardware failures.

Note2: CCFL Life time: 12,000 hours minimum under normal module usage.

Note3: MTBF (Excluding the CCFL): 30,000 hours with a confidence level 90%



Product Specification

AU OPTRONICS CORPORATION

B170PW06 V2

10. Mechanical Characteristics

10.1 LCM Outline Dimension

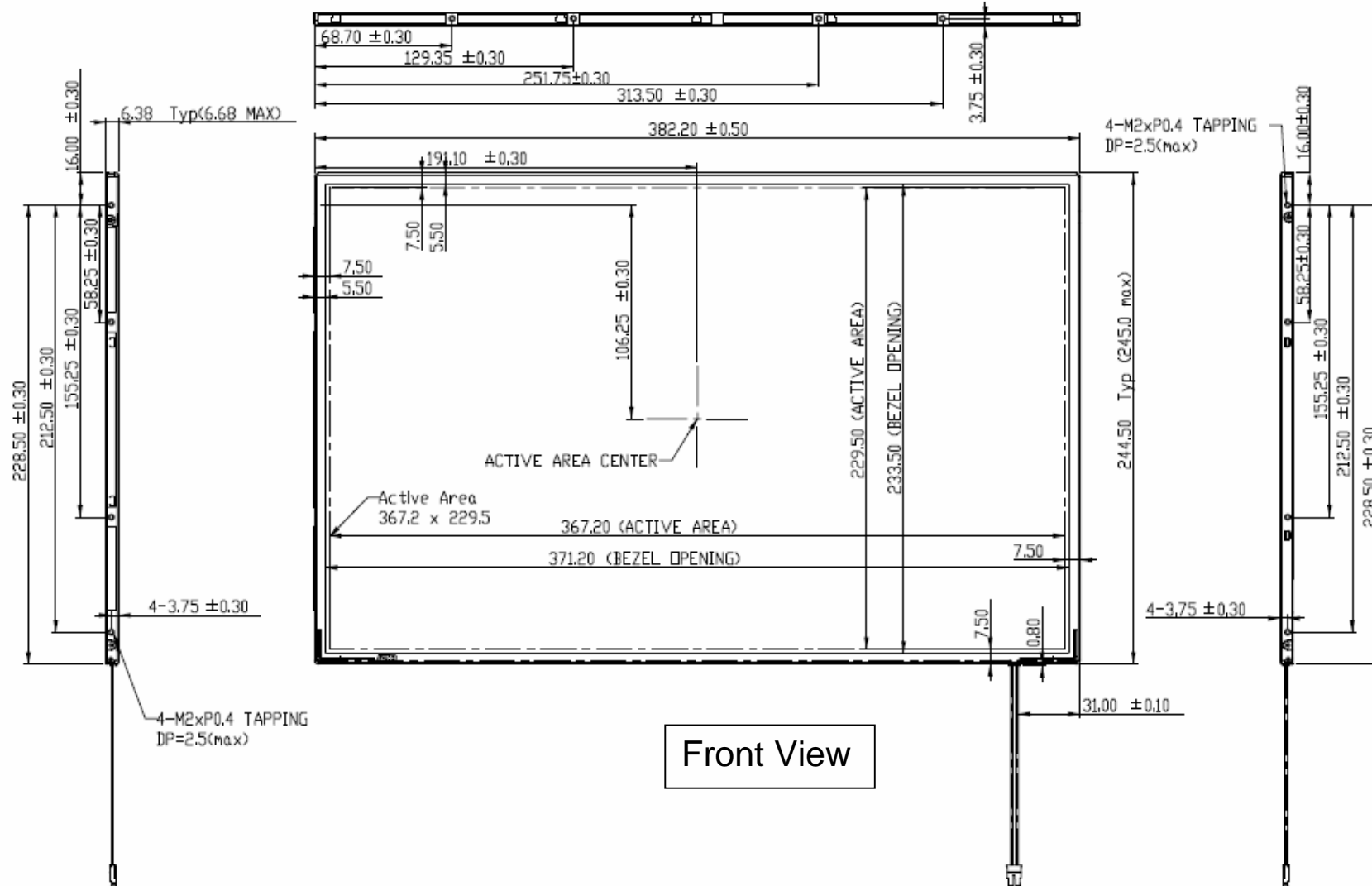



Product Specification

AU OPTRONICS CORPORATION

R170PW06 V2

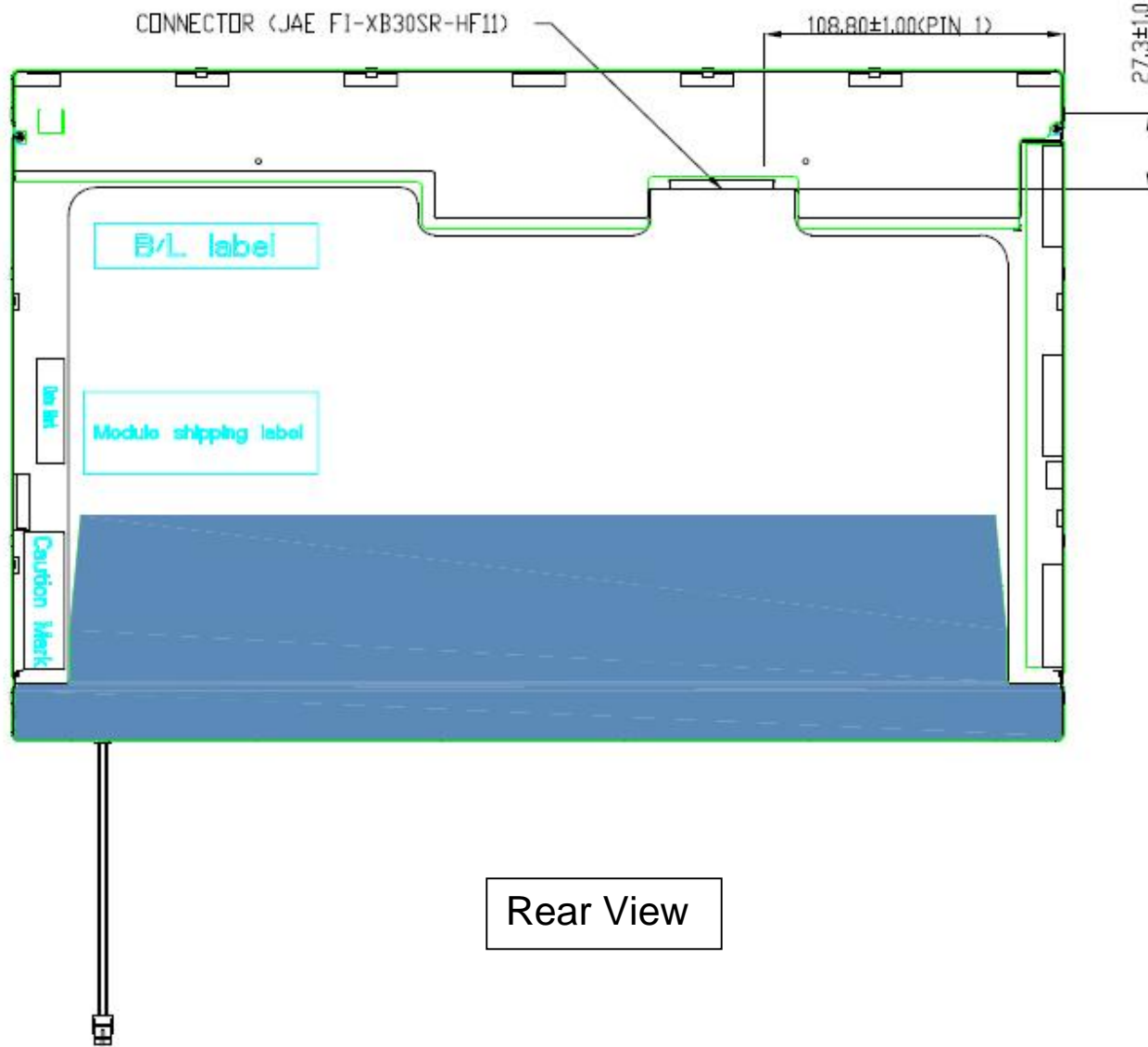

10.2 Screw Hole Depth and Center Position

Screw hole minimum depth, from side surface = 2.8 mm (See drawing)

Screw hole center location, from front surface = 3.75 ± 0.3 mm (See drawing)

Screw maximum length = 2.5 mm (See drawing)

Screw Torque: Maximum 2.5 kgf-cm

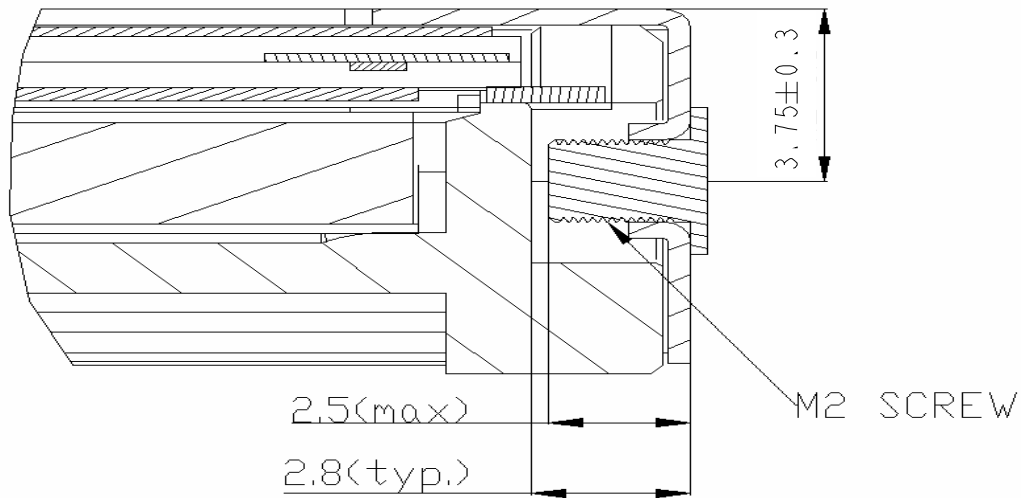

11. Shipping and Package

11.1 Shipping Label Format

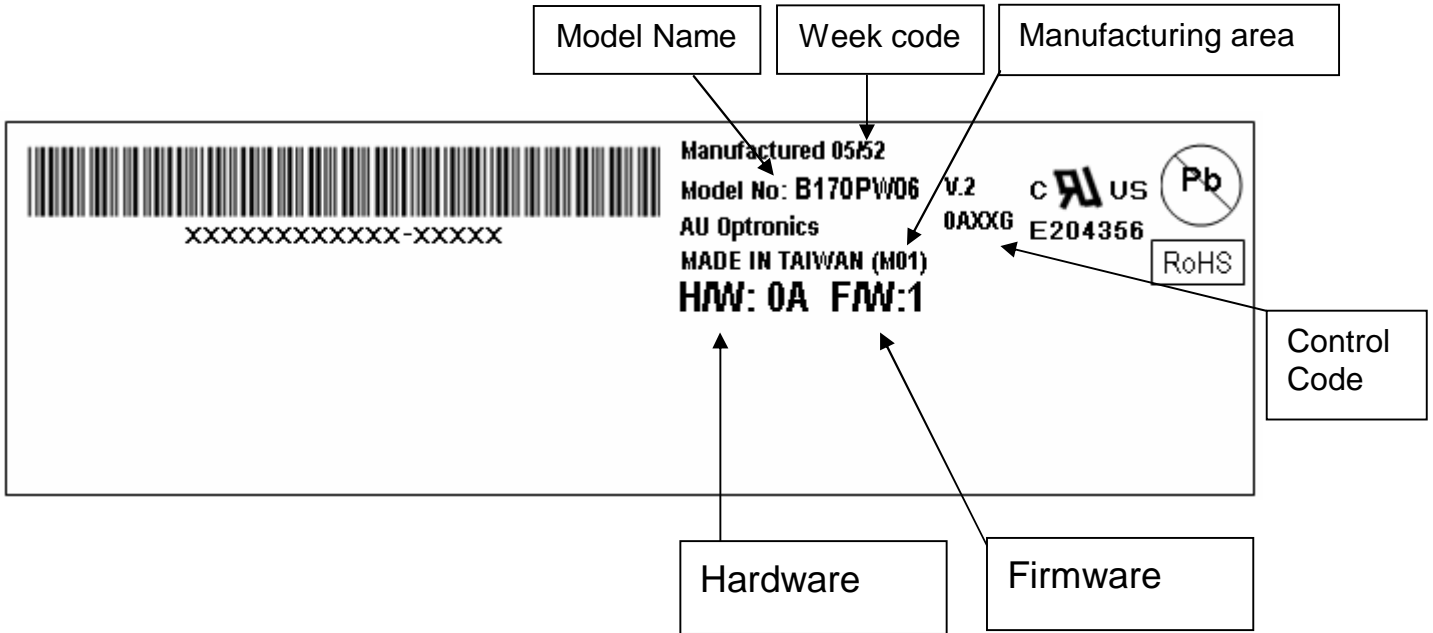

11.2. Carton Package

Packing is 20 pcs / box.

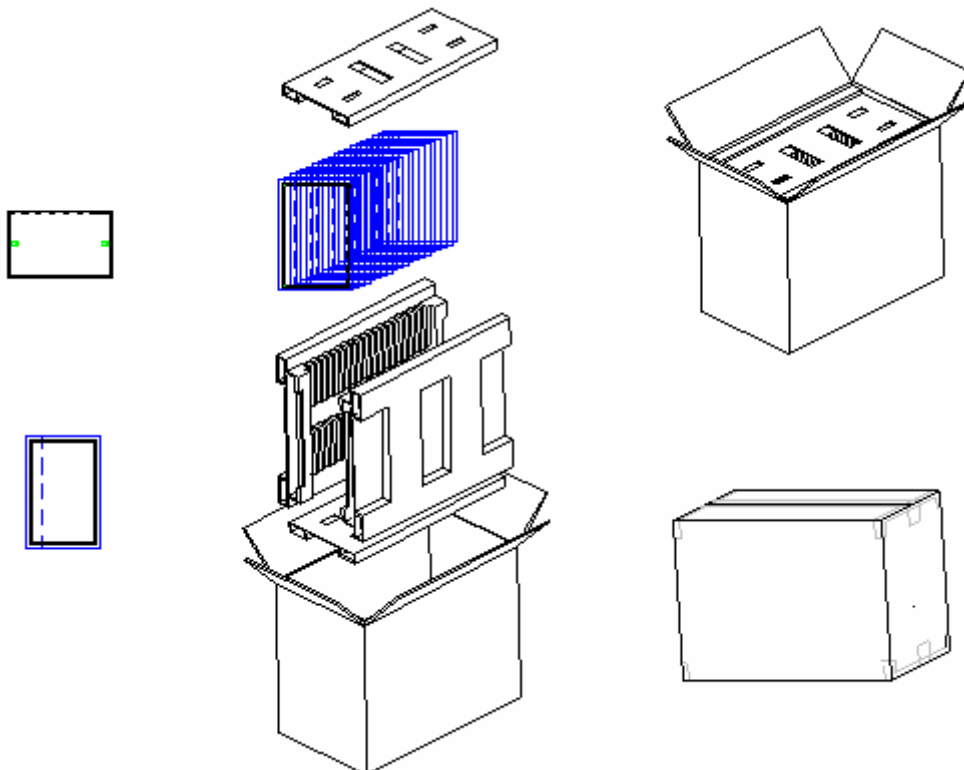



Product Specification

AU OPTRONICS CORPORATION

B170PW06 V2

12. Appendix: EDID description

TBD